

Cablecraft®

Cablecraft Motion Controls

CABLECRAFT ASSEMBLERS

Proudly Building the Best



*Linking Motion
& Control...
The Cablecraft
Solution*

Cable Assemblers Catalog

| | |
|---|-------------|
| ■ Cablecraft® Cable Design | .3 |
| ■ Industrial Controls Cautions | .4 |
| ■ Considerations | .5 |
| ■ Cable Identification | .6 |
| ■ Push-Pull Cable Identification Chart | .7-8 |
| ■ Push-Pull Cable Specifications | .9 |
| Order Code | .10 |
| ■ Push-Pull Blue Max™ | .11 |
| Order Code | .12 |
| ■ Control Head Cable Specifications | .13 |
| Order Code | .14 |
| Micro Adjust/Twist Lock/Non Lock | .15 |
| Commercial | .15 |
| PTO Cables and Mounting Kits | .16 |
| Specialty Cables | |
| ■ Brake Cables (Pull-Only) | .17-21 |
| ■ Brake Levers | .22-25 |
| ■ Truck Clutch Cables (Pull-Only) | .26-27 |
| ■ High-Performance Clutch Cables | .28 |
| ■ Throttle/Accelerator Cables (Pull-Only) | .29 |
| ■ Medium / Heavy-Duty Throttles | .30-31 |
| ■ Remote Valve Control (Spool Valve/ Husco Valve) | .32-34 |
| ■ Modulator Cables | .35 |
| ■ Auto-Shift Cables | .36 |
| ■ MTS Cables (Manual Transmission System) | .37 |
| ■ VGS Systems (Vertical Gear Shifters - 918 Series) | .38 |
| ■ HGS Systems (Horizontal Gear Shifters - 923 & 925 Series) | .39-40 |
| ■ Unidrum | .41-42 |
| ■ Industrial Controls Warnings | .43 |
| ■ Hardware/End Fittings | .44-46 |
| ■ Industrial Linkages | .47 |
| ■ Technical/Application Data | .48-51 |
| ■ Rod Ends | .52-56 |
| ■ Ball Joints | .57-58 |
| Cablecraft Motion Controls Locations | .back cover |

Cablecraft® Control Cables

- Economical replacement for hydraulic, pneumatic or electric systems.
- The most flexible control cable in the industry.
- Interchangeable with other control cables.

All cable assemblers stock original Cablecraft components for immediate assembly of control cables to meet your requirements. No other mechanical control system offers the versatility in routing or the efficiency and dependability of control cables. They can be used for most situations requiring the remote transfer of linear motion. Among these many applications, Cablecraft control cables are most widely recognized for operation of the following mechanisms:

- Throttles
- Clutches
- Latches
- Hitches
- Chokes
- Shifters
- Valves
- Dumps
- PTOs

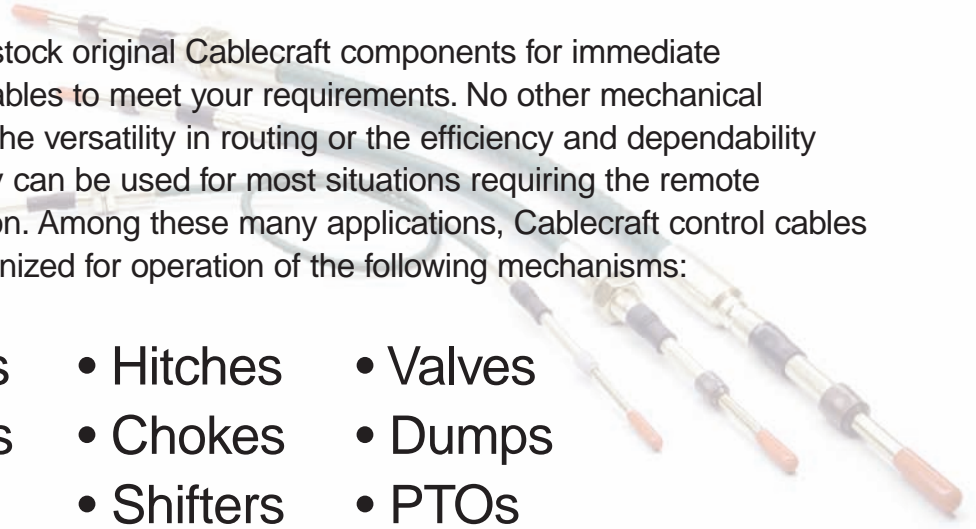

Remember to have this information ready whenever possible:

- Diameter (thread size) of the end rods: 10-32, 1/4-28, 5/16-24, 3/8-24?
- Type of conduit caps: Threaded (T) or Grooved (G)? TT, TG, GG combination?
- Travel: How far does the end rod move? (Pages 7-8)
- Overall length of the cable from end-to-end?
- Does it need to push and pull or simply pull only?

It helps to have this additional information:

- What's the application: Throttle, brake, clutch, shift, etc.?
- Load info: How many pounds do you need to move?
- Conditions/environment: Dirt, heat, cold, moisture, etc.?
- Part number: Are there any part numbers on the existing cable?

Time Proven Design

The design of today's Cablecraft® control has evolved from over 50 years experience in meeting a wide variety of industrial, marine and aircraft applications. Combined with careful selection of materials and fabrication methods, this design provides users the most versatile, highest quality control available today.

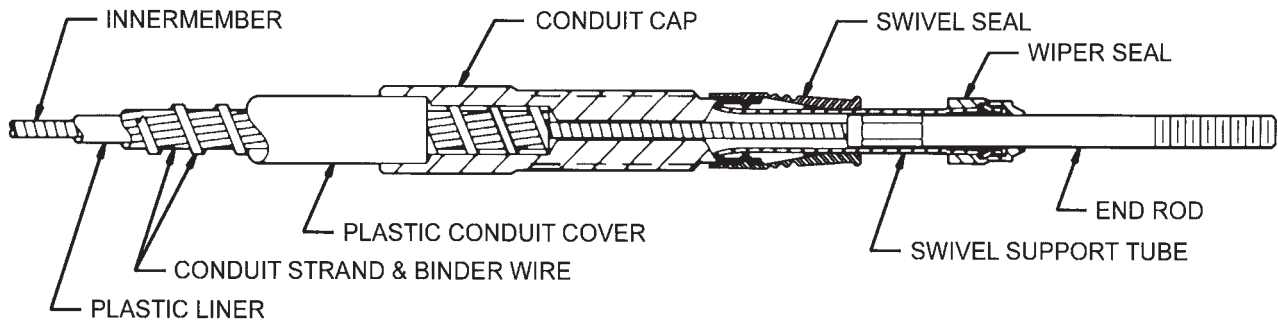

Conduit: First to develop the “binder wire”, Cablecraft’s superior design out performs the competition’s “imitations”.

Utility: Gray plastic covering. Used on 173, 174 & 175 series cables.

Low Friction EXT: Green plastic covering. Used on 313, 314, 315, 183, 184 & 185 controls.

Innervmember: Made of flexible 1x19 carbon strand, armored with a swaged steel jacket for smoothness and compression strength.

173 — Carbon steel jacket.

174 & 175 — Stainless steel jacket.

313, 314 & 315 — Extruded nylon cover over carbon steel jacket.

183, 184 & 185 — PTFE cover.

Lubrication: All standard Cablecraft controls are lubricated during construction with carefully selected compounds to provide optimum performance. No further service is necessary or recommended.

End Rods: All end rods are 300 series stainless steel burnished to a flawless finish.

Wiper Seals: Designed to prevent entry of moisture and contamination into the support tube and provide a bearing surface for the end rod. Improved Model 5 seals (brown) are standard and Model 6 seals (gray) are optional for severe conditions.

Support Tube and Swivel Seal: The swivel joint between the support tube and conduit cap is designed to allow 8 degrees swivel from control center line.

Plated steel — 173, 313 controls.

Stainless steel — 174, 175, 314, 315, 184 & 185 controls.

The swivel seal protects this joint from entry of moisture and contamination.

Conduit Caps: Threaded for bulkhead installation or grooved for clamp application.

Plated steel — 173, 174, 313, 314, 183 & 184 controls.

Stainless steel — 175, 315 & 185 controls.

Technical/Application Data

Industrial Controls Cautions

The following cautions describe application and installation information

1. Do not install Cablecraft®/Bristow® control cables on any application which may exceed any of the design parameters of the control cable.
2. Cablecraft®/Bristow® control cables are designed and assembled to be non-repairable. Do not attempt to modify this control cable.
3. Cablecraft®/Bristow® control cables are designed to be contaminant resistant: not contaminant proof. Protect the cable from contaminants such as gas, oil, diesel fuel, water, dirt, and chemicals which may damage the control cable.
4. Protect the Cablecraft®/Bristow® control cable from physical damage by paint, kinking, vibration, etc., which may damage the control cable.
5. Cablecraft®/Bristow® control cables have the best load capacity in the pull mode. Always install the control cable so it pulls the greatest load, and pushes the smaller load; and pulls the item into the neutral or off position.
6. Do not install the Cablecraft®/Bristow® control cable with power on or the engine running. Serious injury or death could result.

7. The usable stroke must be centered within the available travel.

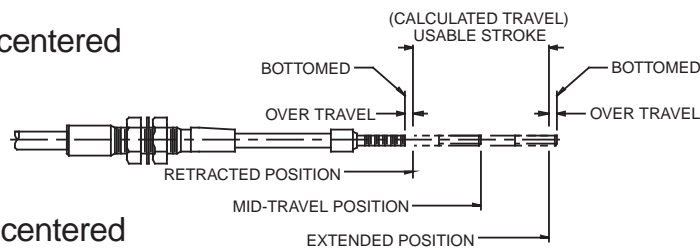

FIG 1

8. The conical swivel must be centered within the available swivel angle.

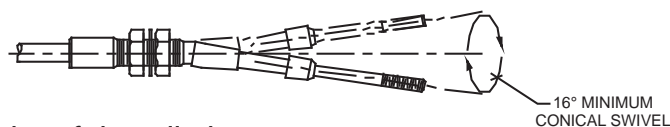

FIG 2

9. This cable is not for use on aircraft installations.

Cable Considerations

There are many factors that affect cable operation and performance. Please consider the following when planning your cable applications.

Bend Radius: All cables have a minimum bend radius that should not be exceeded (see push-pull cable specifications). Any excessive bends or kinks will prevent the cable from operating properly.

Total Degrees of Bend: As the degrees of bend increase, cable efficiency decreases. Keep the bend radius as large as possible and the degrees of bend to a minimum for optimal performance.

Backlash (lost motion): Motion lost between the input end rod and the output end rod is due to factors such as the amount of clearance between the conduit and innermember, applied loads, degrees of bend, overall length and material characteristics.

Efficiency: The amount of force lost between the input load and the output load is due to factors such as friction, increasing loads, etc. As efficiency decreases, the cable becomes harder to operate.

Length: As length increases, cable efficiency may decrease. Maximum lengths depend on materials, degrees of bend, load, etc.

Loads: All cables have limited load capacities (see push-pull cable specifications). Prudent choice of cable capability/size will enhance life and performance.

Environment: Factors such as temperature, moisture, dirt/contamination can significantly affect cable performance and life. Choose our standard Model 5 wiper seal for normal conditions or Model 6 seal for severe environments.

Warranty:

In short, Cablecraft® Assemblers warrant material, workmanship and conformance (will perform) to catalog specifications for one year from date of manufacture.

Contact your local cable assembler to submit a cable for warranty consideration.

A copy of Cablecraft's complete warranty statement is available at

<http://www.cablecraft.com>

CONTACT YOUR LOCAL CABLE ASSEMBLER FOR ADDITIONAL INFORMATION.

Standard Push-Pull Cable Terminology

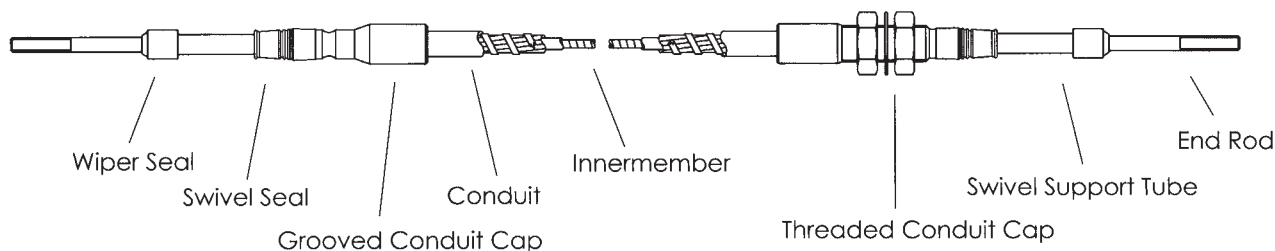

How to Identify Push-Pull Cables

Your goal is to determine the information required to make up the “ordering code” or part number. An example of a typical ordering code is 173-VTG-3-144.

173 - VTG - 3 - 144

Step 1: Determine the “**duty**” (size) of the cable by the diameter and threads of the end rods. **V** = 10-32, **L** = 1/4-28, **M** = 5/16-24, **H** = 3/8-24.
(Very light duty; Light duty; Medium duty; Heavy duty)

Step 2: Determine the type of **conduit end** fittings (conduit caps) for left end and right end. **T** = Threaded, **G** = Grooved. TT, GG or TG combinations.

Step 3: Determine the **travel** of the end rod. 1” through 6” in one inch increments.

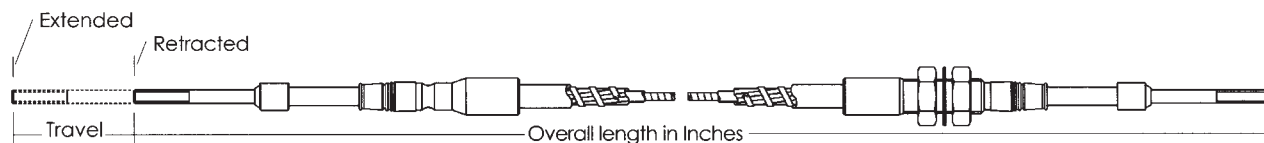

Step 4: Determine the overall **length** of the cable.

Step 5: Determine cable materials depending on usage and conditions.
See details of 173, 174, 175 Utility, 313, 314, 315 Low Friction EXT and 183, 184 and 185 Low Friction.

Utility: “The Rugged Gray Cable” is the industry-standard and is designed for a long life under rugged conditions (173, 174, 175).

Low Friction EXT: “The Green Cable” is the proper cable to use when superior efficiency is required. The extruded nylon cover over the innermember works very smoothly with the polyliner (313, 314, 315).

Low Friction: The proper cable to use when superior efficiency is required. The bonded PTFE cover over the inner operating member works very smoothly with the plastic liner (183, 184, 185).

Push-Pull Identification Chart

Visual Comparison Chart for Determining Travel

To determine the "travel" on an existing cable, you can compare the length of the support tubes with the illustrations below and on the next page. Determine the "duty" (size) of the cable by the diameter and threads of the end rods. **V** = 10-32, **L** = 1/4-28, **M** = 5/16-24, **H** = 3/8-24. (Very light duty; Light duty; Medium duty; Heavy duty)

Very Light Duty

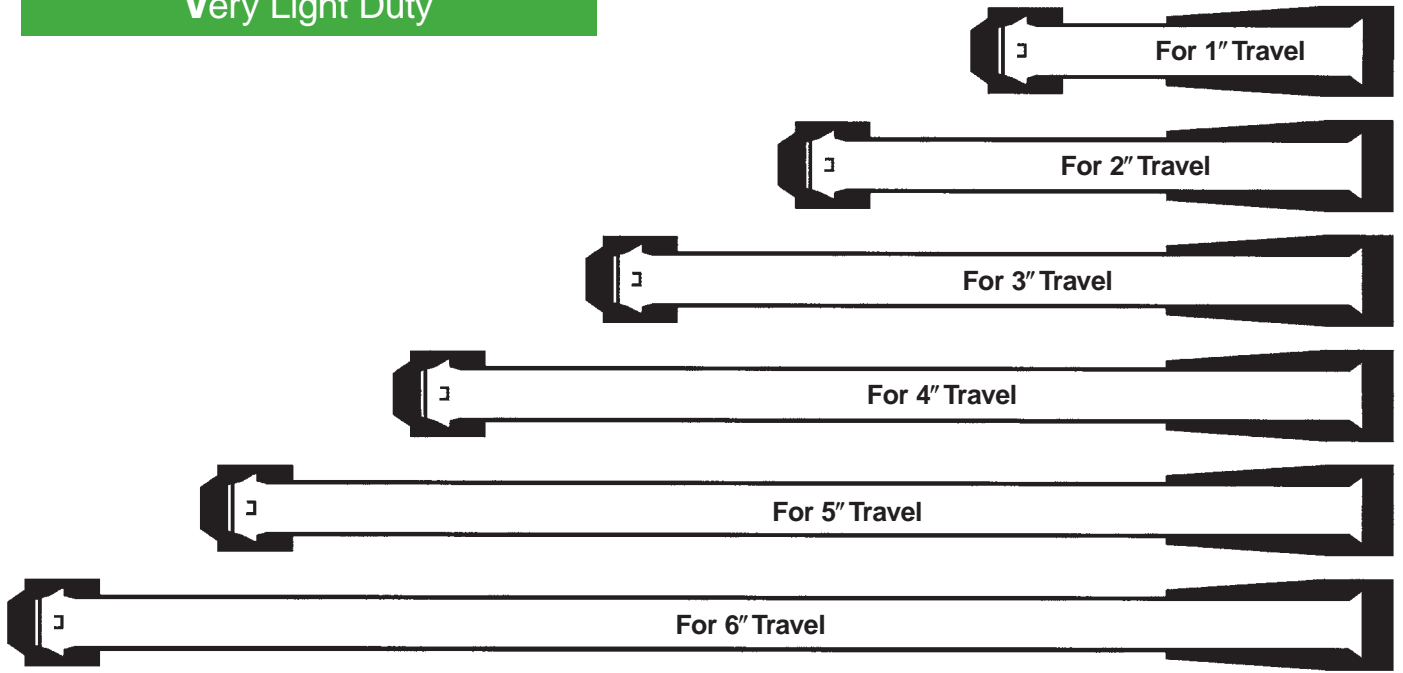

Light Duty

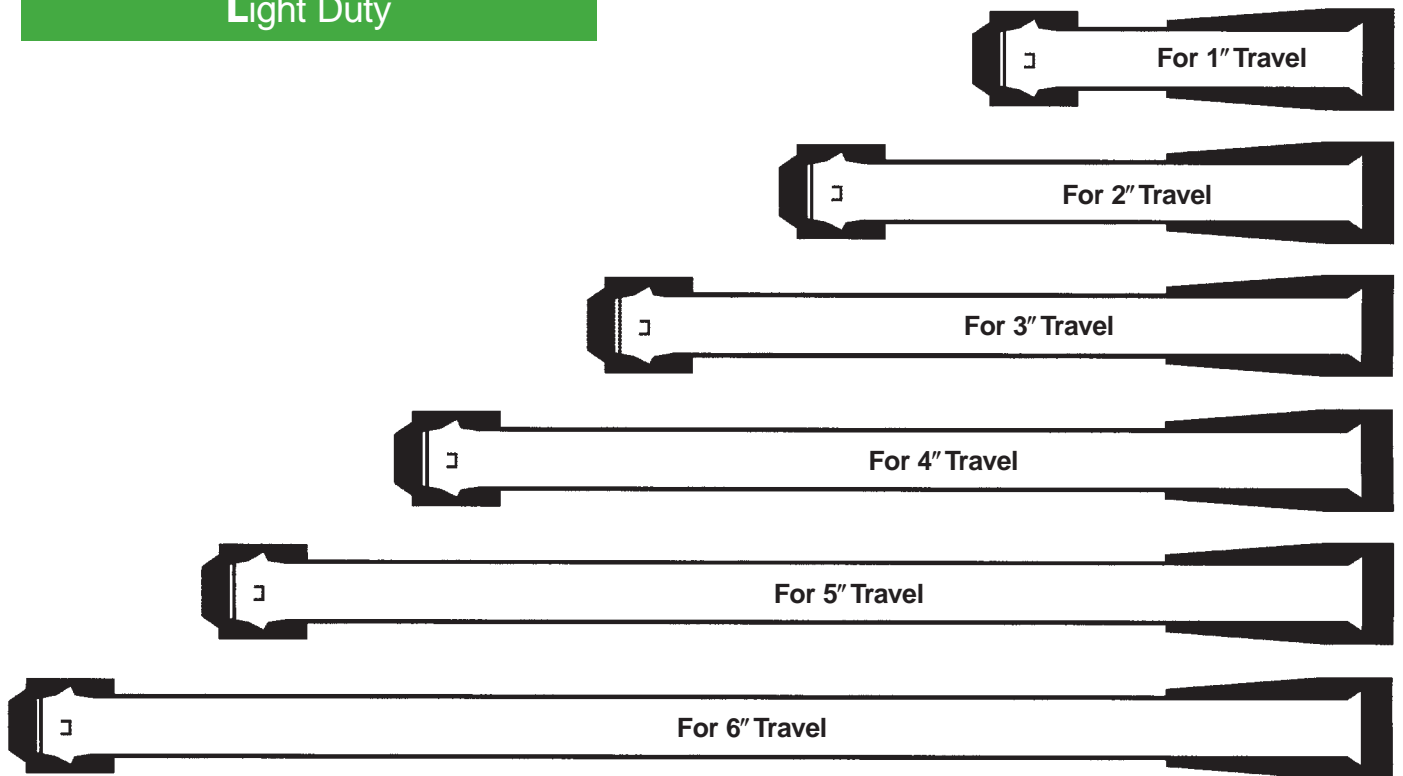

Medium Duty

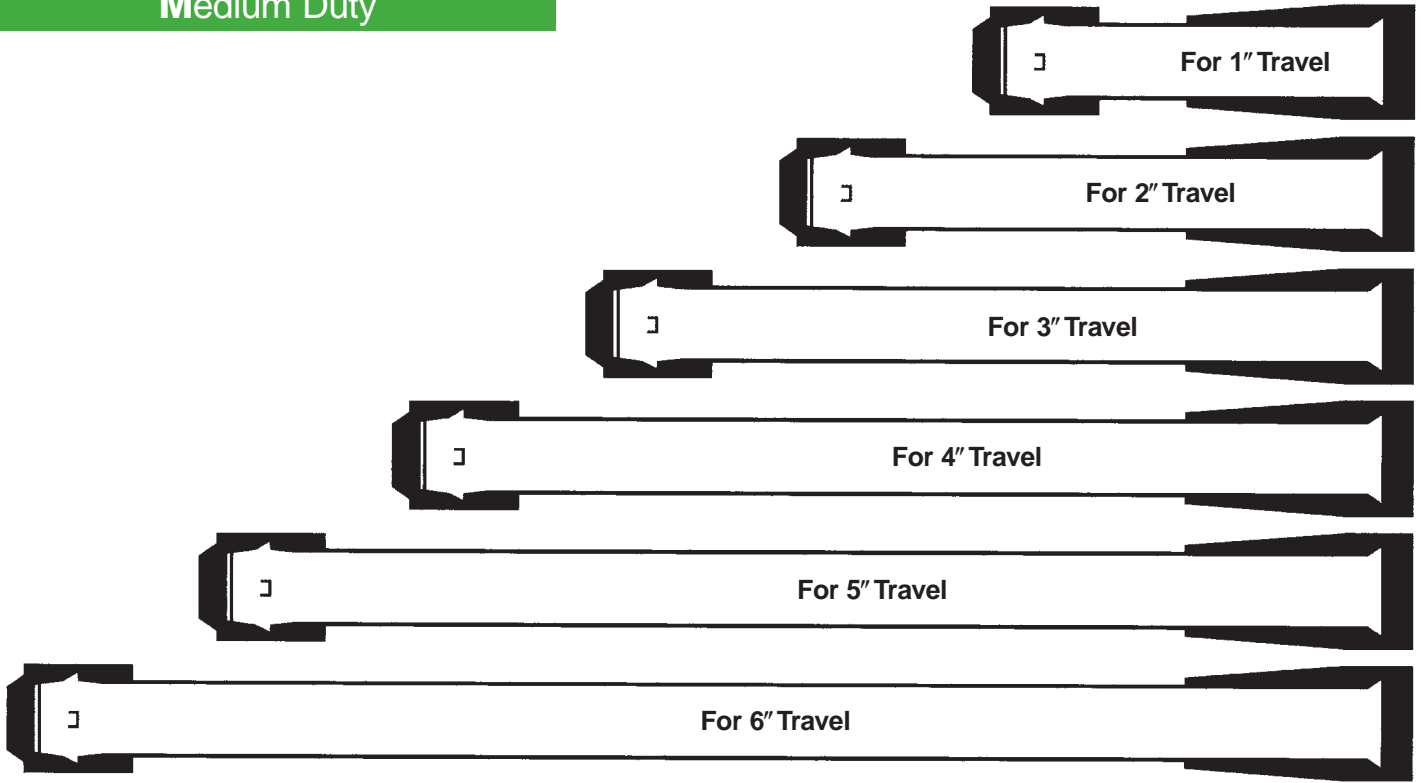

Heavy Duty

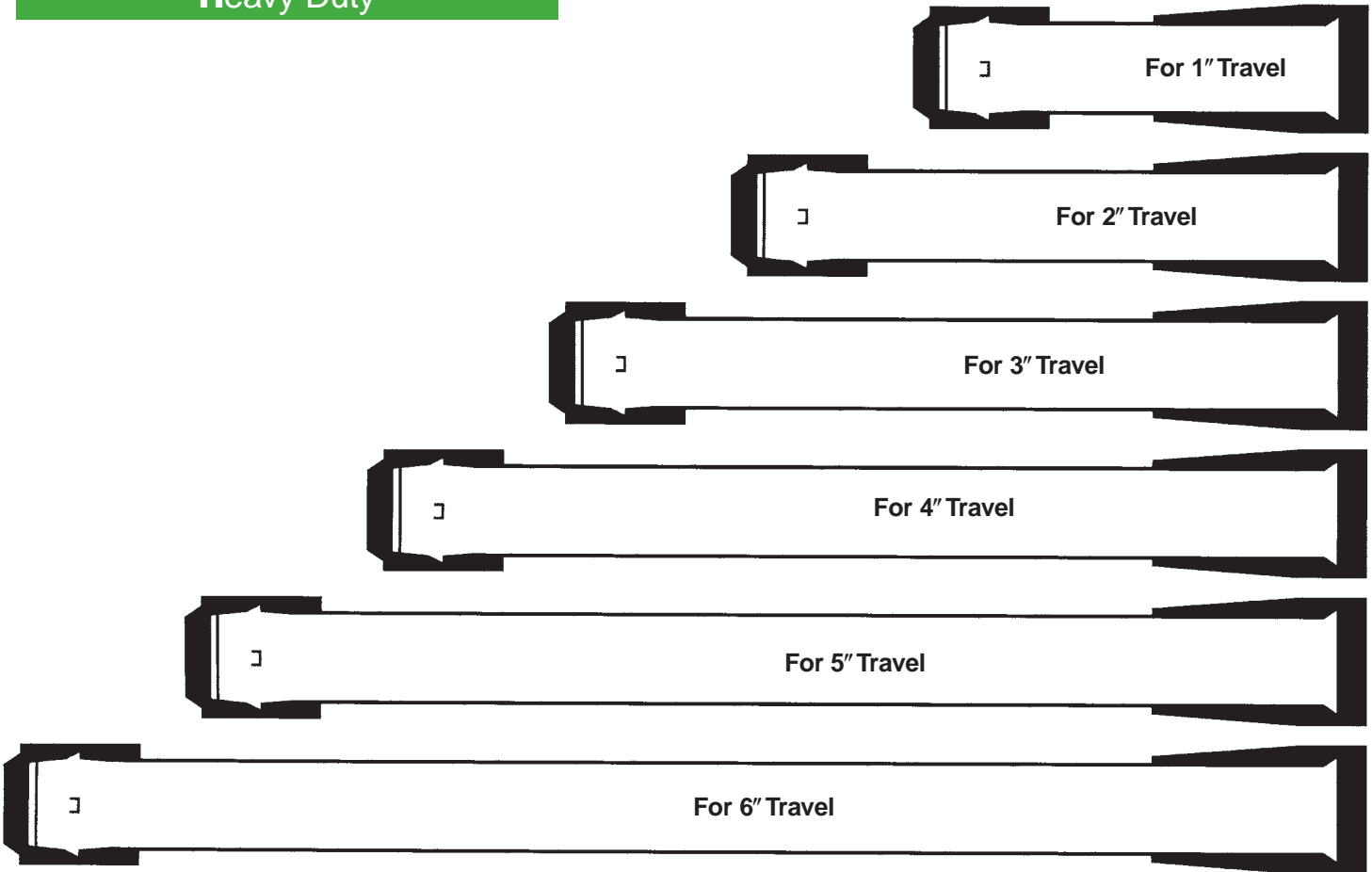

Push-Pull Cable Specifications

| | A Dimension Threaded Swivel (in) (control at mid travel) | Minimum Travel Push-Pull (in) | Working Input Load (lbs) Push-Pull | Maximum Input Overload (lbs) | A Dimension Grooved Swivel (in) (control at mid travel) | | |
|------------|---|---|---------------------------------------|--|--|--|--|
| VLD | | 4.38 5.87 7.38 8.87 10.38 11.87 | 1" 2" 3" 4" 5" 6" | 80/120 80/120 70/120 60/120 45/120 30/120 | 120/180 120/180 110/180 90/180 70/180 45/180 | 3.69 5.19 6.69 8.19 9.69 11.19 | |
| LD | | 4.62 6.12 7.62 9.12 10.62 12.12 | 1" 2" 3" 4" 5" 6" | 150/230 150/230 125/230 100/230 75/230 50/230 | 230/350 230/350 190/350 150/350 110/350 75/350 | 4.00 5.50 7.00 8.50 10.00 11.50 | |
| MD | | 5.06 6.56 8.06 9.56 11.06 12.56 | 1" 2" 3" 4" 5" 6" | 250/400 250/400 210/400 170/400 130/400 100/400 | 400/600 400/600 300/600 250/600 200/600 150/600 | 4.38 5.87 7.38 8.87 10.38 11.87 | |
| HD | | 5.69 7.19 8.69 10.19 11.69 13.19 | 1" 2" 3" 4" 5" 6" | 700/1000 700/1000 600/1000 500/1000 400/1000 300/1000 | 1000/1500 1000/1500 900/1500 750/1500 600/1500 450/1500 | 5.19 6.69 8.19 9.69 11.19 12.69 | |

Low Friction-EXT and Utility Cables Design Criteria

Efficiency:

Efficiency factor ratings are for comparative purposes and may vary due to length, rate of travel, direction of travel, bend radius and temperature.

To Compare Efficiency:

Input force = Output load (lbs) x total degrees of bend x efficiency factor + output load.

Efficiency Factors:

Low Friction-EXT .0012
Utility .002

| Duty | Minimum Bend Radius |
|------|---------------------|
| VLD | 2" |
| LD | 3" |
| MD | 5" |
| HD | 6" |

Backlash:

Nominal Backlash = Backlash factor x total degrees of bend.

Backlash Factors:

VLD .00015 MD .00025
LD .00020 HD .00030

Temperature Range: -65° to +230°F

Push-Pull Standard Order Code

Cablecraft® Ordering Codes

314 - (6) - L - TT - 3 - 144 - (AP)

Control Type

Low Friction-EXT

- 313 with Stainless Steel End Rods
- 314 with Stainless Steel Support Tubes and End Rods
- 315 all Exposed Fittings/Parts are Stainless Steel

Utility

- 173 with Stainless Steel End Rods
- 174 with Stainless Steel Support Tubes, End Rods and Innermember Armor
- 175 all Exposed Fittings/Parts are Stainless Steel plus Stainless Innermember Armor

Low Friction

- 183 with Stainless Steel End Rods
- 184 with Stainless Steel Support Tubes and End Rods
- 185 all Exposed Fittings/Parts are Stainless Steel

Seal Options

- 6 (Use this number only if requesting optional Model 6 wiper seal, optional on all controls)

Cable Size

- Letter End Rod Thread
- V 10-32 UNF
- L 1/4-28 UNF
- M 5/16-24 UNF
- H 3/8-24 UNF

End Fitting Combinations (Options: GG, TG, TT)

- T Threaded Swivel
- G Grooved Swivel

Cable Travel: 1, 2, 3, 4, 5, 6 (inches)

Length +/- .25 (inches)

Suffix Letters for Additional Features

(Use only if requesting optional features)

- N End Rod Jam Nuts (2 each)
- W Extra Shakeproof Washers on Conduit Ends
- A Combination of N and W
- P Stamp with Customer Part Number
- S Stamp with Cablecraft and Customer Part Number
- M Metric End Rods (optional)
 - V M5 x .8
 - L M6 x 1.0
 - M M8 x 1.25
 - H M10 x 1.5

Push-Pull Blue Max™

Marine Applications:

- Shift
- Throttle
- Trim

*Not Intended For Use
as Steering Cable*

Racing Applications:

- Shift
- Fuel Shut Off
- Chute Release
- Throttle

*Not Intended For Use
as Steering Cable*

Features:

- Travel: 3.00"
- Bulkhead type (threaded) conduit caps, stainless steel
- Clamp type (grooved) conduit caps, stainless steel
- 10-32 end rod threads
- BB, BC, CC options are all available
- High temperature

Material:

- 1 x 19 Stainless Steel Wrapped Innermember
- RHOS Rated
- Stainless Steel
- LDPE Covered (Blue) Conduit
- Binder Wire Conduit Core PTFE



Cablecraft Motion Controls' New Blue Max™ cable line is the high performance control cable to solve your push-pull requirements. This superior control is born of aviation engineering design, with extreme low friction and minimal loss of motion. Offering unparalleled performance with the finest, smoothest feel in the industry.

This outstanding design is excellent for long runs with complicated cable routing while being extremely efficient on shorter runs.

Along with a true 4-inch minimum bend radius, lubed for life, and binder wired PTFE core conduit, the outer jacket is resistant to abrasions, gasoline, diesel, and chemicals.

If you are seeing red over your control problems, make the Blue Max high performance line of cables your next move.

All line art dimensions are represented in inches

High Performance Push-Pull Control Cable

Notes: (Design Parameters)
Travel: 3" minimum
Minimum bend radius: 4.00"

Operating temperature:
 from -65°F to +350°F
Slim line grooved conduit cap for marine applications, call for details

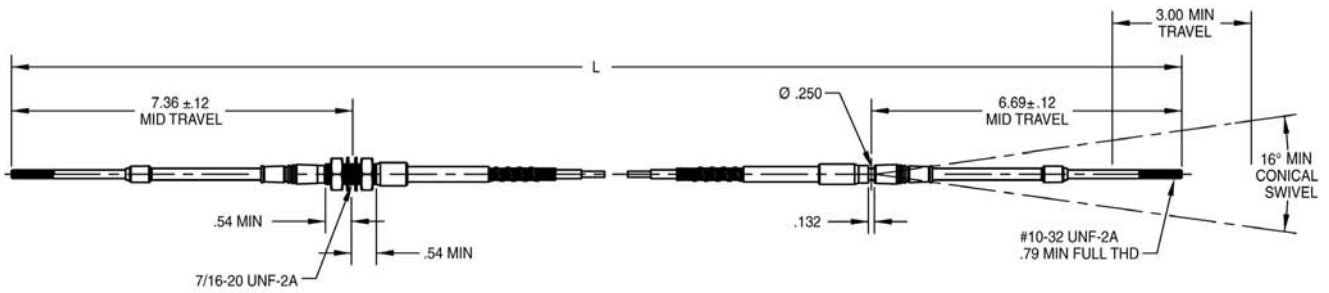

All line art dimensions are represented in inches

High Performance Cable Ordering Codes

795 - 6 - V - TT - 3 - 144

Control Type _____

*(All End Rods are Stainless Steel)

795 All Exposed Fittings/Parts are Stainless Steel – both ends

796 All Exposed Fittings/Parts are Stainless Steel – one end – Carbon Steel Opposite*

Seal Options _____

6 Standard

Cable Size _____

V 10-32 UNF End Rods – Very Light Duty

End Fitting Combinations (TT, TG, GT, GG) _____

| | | | | stainless end | opposite end |
|------------|---|---|------------|------------------|-----------------|
| 795 | T | T | 796 | T | T |
| | T | G | | T | G |
| | G | G | | G | T |
| | | | | G | G |

Cable Travel: 3 (inches) _____

Length +/- .25 (inches) _____

All line art dimensions are represented in inches

Control Head Cable Specifications

| | | | | | |
|---|--|--|--|--|--|
| Micro Adjust | | | | | |
| Twist Lock | | | | | |
| Non Lock <p>Must specify knob - page 14</p> | | | | | |
| Non Lock <p>Must specify knob - page 14</p> | | | | | |

| | Extended Dimensions | Non Lock VLD | Non Lock LD | Twist Lock | Micro Adjust | |
|----------------|---|----------------------------------|----------------------------------|----------------------------------|--|------------|
| VLD | <u>Travel "A"</u> 1" 4.94" 2" 6.94" 3" 8.94" | 81V32 81V42 86V32 86V42 | ----- | 51V32 51V42 56V32 56V42 | 21V32DF 21V42DF 26V32DF 26V42DF | EXT UTL |
| VLD | <u>Travel "A"</u> 1" 4.25" 2" 6.25" 3" 8.25" | 81V33 81V43 86V33 86V43 | ----- | 51V33 51V43 56V33 56V43 | 21V33DF 21V43DF 26V33DF 26V43DF | EXT UTL |
| LD | <u>Travel "A"</u> 1" 5.18" 2" 7.18" 3" 9.18" | | 91L32 91L42 96L32 96L42 | 51L32 51L42 56L32 56L42 | 21L32DF 21L42DF 26L32DF 26L43DF | EXT UTL |
| LD | <u>Travel "A"</u> 1" 4.56" 2" 6.56" 3" 8.56" | | 91L33 91L43 96L33 96L43 | 51L33 51L43 56L33 56L43 | 21L33DF 21L43DF 26L33DF 26L43DF | EXT UTL |
| VLD | | CA215 | | CA217 | CA219 | UTL |
| LD | | | CA216 | CA218 | CA220 | UTL |

Control Head Cable Order Code

Cablecraft® Ordering Codes

2 - 1 - L - 3 - 2 - DF - (6) - 3 - 120 /

Control Head Type

- 2 = Micro Adjust
- 5 = Twist Lock with 2.38" Plastic Handle
- 6 = Twist Lock with 3.5" Metal Handle
- 7 = Non-Locking with 3/8"-24 UNF Mounting
- 8 = Non-Locking with 7/16"-20 UNF Mounting
- 9 = Non-Locking with 5/8"-18 UNF Mounting

Cable Type

- 1 = Low Friction-EXT
- 3 = Low Friction
- 6 = Utility
- 9 = Bristow

Cable Size

- V = Very Light Duty
- L = Light Duty

Stainless Steel Options

- 0 = Carbon Steel Fittings
- 3 = with Stainless Steel End Rod
- 4 = with Stainless Steel End Rod, Support Tube and Innermember Armor

Output End Fittings

- 2 = Threaded Twist On
- 3 = Grooved Twist On
- 4 = Threaded Swaged
- 5 = Grooved Swaged
- 6 = Closed End Swaged

Micro Adjust only Cable Options

- D = Disconnect Feature
- F = Friction Lock Accessory

Seal Options (Use this number only if requesting optional seals)

- 5 = Improved Model 5 Wiper Seal is Standard on Low Friction-EXT & Utility
- 6 = Model 6 Wiper Seal, Optional on All Controls

Cable Travel — 1" - 3" (For Output Fittings Style 2 & 3 Only)

Overall Length — (See overall length dimension points indicated on each illustration)

Knob Option — (For Control Head Types 7, 8 and 9, see page 1H for handle options)

Control Heads Commercial

Factory assembled, trim-to-length, with stainless steel solid wire innermember. Up to 3" travel, 5" minimum bend radius and 20 lb pull load rating.

Micro Adjust
 Part No. 29V00-L (without Friction Lock)
 Part No. 29V000F-L (with Friction Lock)

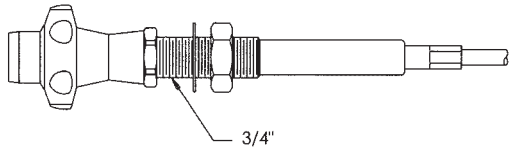

Twist Lock
 Part No. 59V00-L

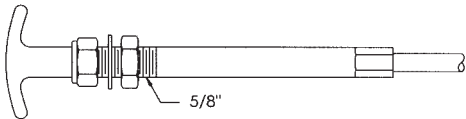

Non Lock (shown with 306 knob)
 Part No. 79V00-L

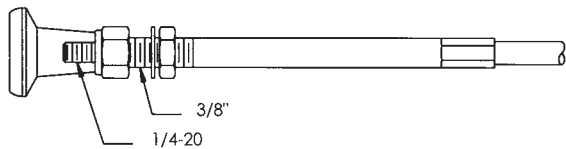

Twist-On Conduit Ends
 (Standard for Control Heads on left)
 Part No. 161-775 (3/8" Dia.)



Optional for Control Heads on left
 3/8-24 UNF, Part No. 161-581



Optional for Control Heads on left
 3/8" Dia., Part No. 161-579

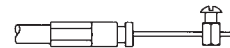

Friction Lock Kit
 Part No. 165-510-215

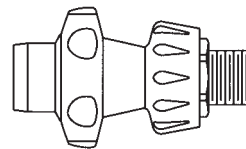

For part number 29V00. Includes adjustment ring and compression washer.

Truck Throttle Control
 Part No. 286-009-L ("L" = Length)

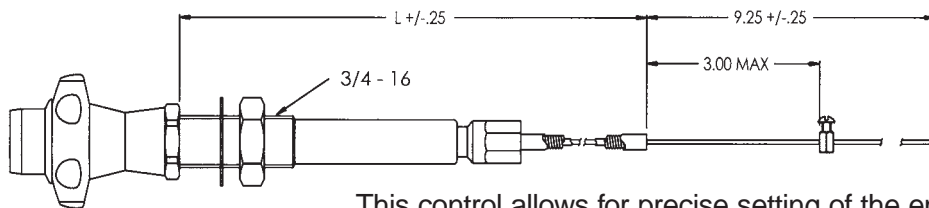

This control allows for precise setting of the engine RPM when the PTO is engaged or as a manual control of the idle position during engine warm up (Friction Lock optional).

Non-Locking, Non-Rotating Control Head
 Part No. 165-437-L Black Knob ("L" = Length), Part No. 165-438-L Black T-Handle ("L" = Length)

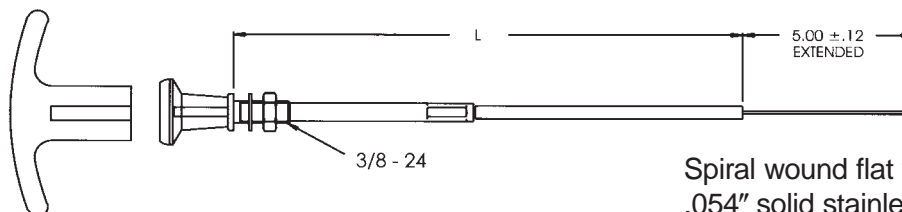

Spiral wound flat wire conduit
 .054" solid stainless innermember

Control Heads PTO Cables

Standard Replacement PTO Control Cable Part No. 872-507-L

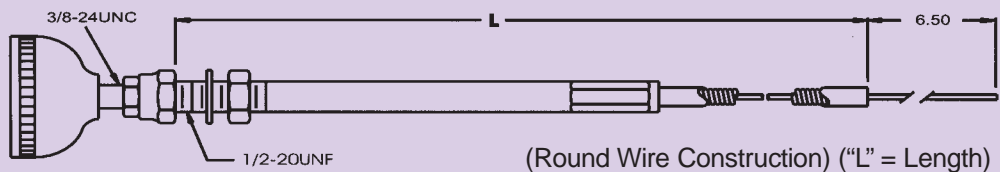

The quality replacement cable for power take-off control that equals or surpasses original equipment standards. Adaptable to mounting brackets of Muncie®, Chelsea® and similar cable-actuated PTOs.

PTO Cable Attachment Kit (For use with non lock control head)

Cable and handle sold separately.

Attach your custom-built cable to Chelsea® or similar PTO units with the same mounting pattern that have a 3 inch hole-center to hole-center lever arm.

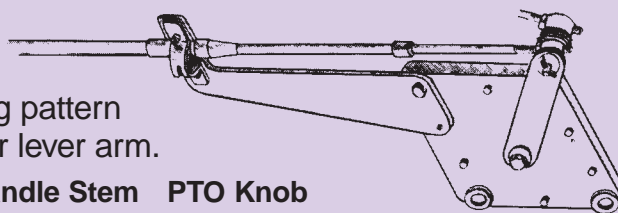

| Attachment Kit | Cable Size | Cable P/N | Handle Stem | PTO Knob |
|----------------|------------|----------------|-------------|-------------|
| 175-600-004 | VLD | 86V33-3-Length | 1/4-28 | 165-183-001 |
| 175-600-005 | LD | 96L33-3-Length | 5/16-18 | 165-183-003 |

Optional Knobs for Non Lock Control Heads

Part numbers shown below are of reinforced black nylon. Specify knob in part number for all non-locking controls (included in price).

| Inscription | Part Number | | |
|-------------|-------------|--------|---------|
| | 1/4-20 | 1/4-28 | 5/16-18 |
| None | 005 | 014 | 013 |
| STOP | 015 | 016 | |
| SHUTOFF | 002 | 008 | 018 |
| THROTTLE | 019 | 020 | |

| Inscription | Part Number | |
|-------------|-------------|--------|
| | 1/4-20 | 1/4-28 |
| None | 306 | 308 |
| STOP | 317 | 314 |
| SHUTOFF | 318 | |
| THROTTLE | | 321 |
| CHOKE | 309 | |
| OPEN | | 324 |
| CLOSE | | 326 |

Cast aluminum oversize T-handle (not included in price).

| Inscription | Part Number | | |
|-------------|-------------|--------|---------|
| | 1/4-20 | 1/4-28 | 5/16-18 |
| None | 201 | 202 | 203 |

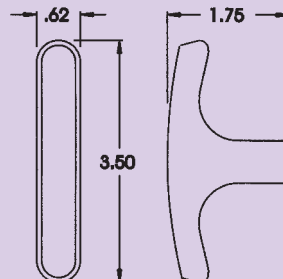

Not Shown: Same handle for Twist Lock Control Head
Handle 300-057-008
Set Screw 175-405-144

Pull-Only Brake Cables

Custom Parking Brake (Pull-Only) Cables

Your local cable assembler can create a pull-only cable control for applications such as parking brakes, clutch cables, and other similar applications. 1500 lb and 3000 lb series cables available. Choose from conduit caps and end fittings shown here to replace or customize your pull-only cable controls.

Cablecraft® has developed a seal system that greatly extends the life of these pull-only control cables. Conduit caps contain a wiper seal to provide maximum protection against the entry of dirt and moisture into the interior of the cable. The innermember is nylon covered, high-tensile galvanized steel strand. The smooth surface of the innermember and the conduit cap seals are the key to extending cable life and efficiency.

The conduit has a plastic liner to provide additional environmental protection. Cablecraft pull-only cables are lubricated during assembly, and because of their design, no further lubrication is required or recommended for the life of the control. Outstanding efficiency is the result of many features incorporated into the Cablecraft design, even after being operated in excess of 250,000 cycles in simulated working conditions.

Control Selection

For proper application of Cablecraft pull-only cable controls, the pull input load should be determined as follows:

1. Measure the output load to be operated.
2. Estimate the total number of degrees of bend in the control installation.
Note: bend radius is not significant as long as it is equal or larger than the minimum recommended.
3. Calculate the required pull input load using an efficient factor obtained from Table 1 and the following equation:
Input load = output load x efficiency factor.
4. Determine cable size. Individual cable drawings indicate ultimate loads. Allowing a 4-1 safety factor will provide a reliable application and will extend cable life.

Table 1

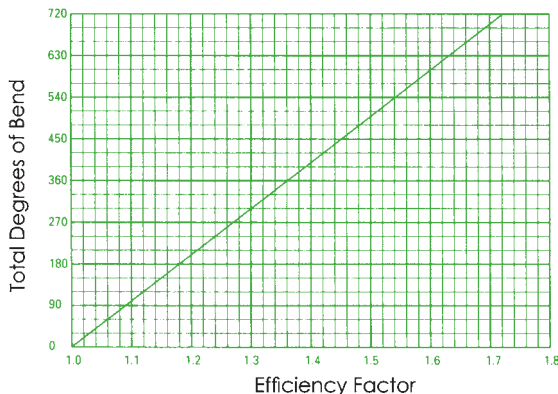

Example Control Selection

1. Maximum output load to be operated = 380 lbs
2. Calculate required pull input load using Table 1.
Input load = output load x efficiency factor
380 lbs x 1.27 = 483 lbs input load
3. Determine cable size: Apply your required safety factor to input load (step 3) to determine ultimate load.
Input load Safety factor Ultimate load
483 lbs x 4 = 1932 lbs

Refer to following pages for control selection.

Ultimate Load

3000 lbs see page DE

1500 lbs or less see pages EI and EJ

Your Safety Factor

Each cable size shows the ultimate load. Safety factors are important in proper cable selection. A wide margin (4 to 1 or 5 to 1) between ultimate load and working load is not only safer, but the cable will operate more easily and greatly extends cable life. Detailed information regarding cable selection is available upon request.

Installation

Care should be exercised to insure that pull controls are installed with conduit end fittings securely fastened to a structural member. The conduit will always be in compression. The total degrees of bend should be minimized for the lowest deflection and friction. On long control runs, the conduit should be clamped to supporting structure at least every 48 inches. Complete application recommendations will be provided on request. A sketch of the proposed installation will aid in selection of the proper control.

Preliminary Ordering Procedure

For Pull-Only Cable Controls

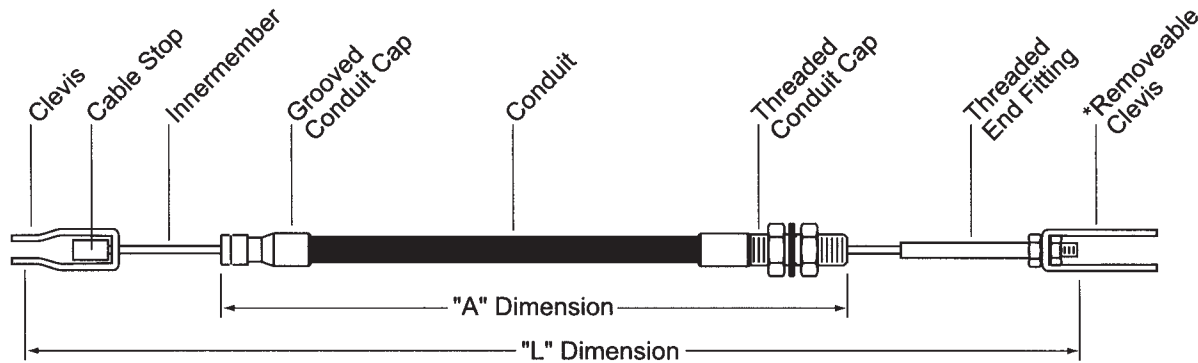

To specify a pull control, the following information must be given in the order listed:

1. Left innermember end fitting part number.
 2. Left conduit end fitting part number.
 3. Length "A" between conduit fitting reference points in inches.
 4. Right conduit end fitting part number.
 5. Right innermember end fitting part number.
 6. Length "L" of innermember assembly between fitting reference points in inches.
 7. Travel of the innermember in the conduit in inches. (Note: dimensions "L" must be sufficiently greater than dimension "A" to allow desired travel).
- *Removeable items should be listed separately.

Cablecraft® Ordering Codes

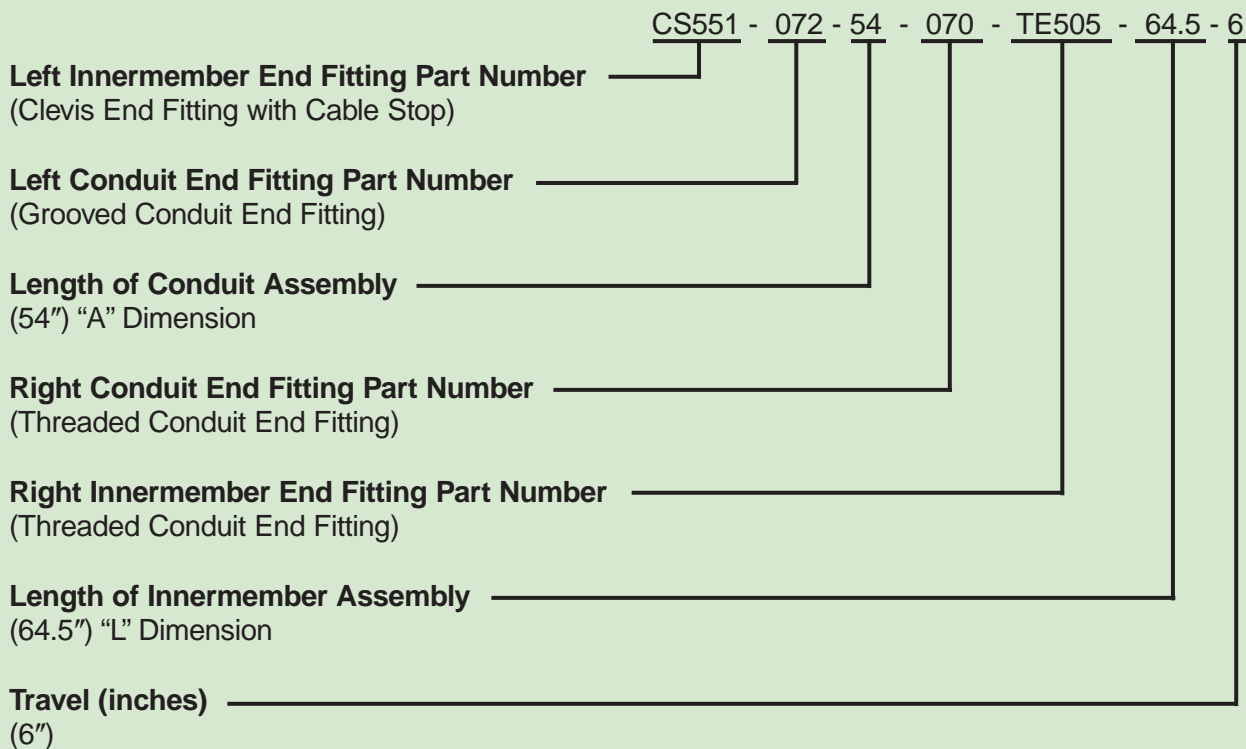

Pull-Only Brake Cables

1500 lb Series Ultimate Load: 1500 lb
 Minimum Bend Radius: 5"
 See page E1 for ordering procedure.

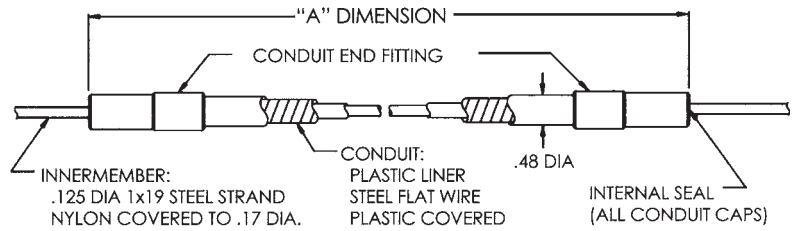

Threaded Conduit End Fitting

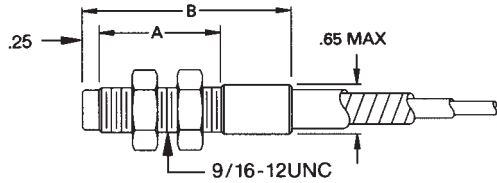

THREADED CONDUIT END FITTING

| PART NO. | A | B |
|----------|-----|-----|
| 060 | 1.4 | 2.7 |
| 061 | 2.1 | 3.4 |

Grooved Conduit End Fitting

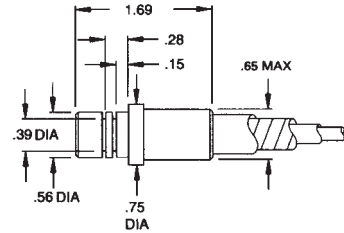

PART NO. Use E-Clip
 064 175-435-025

Grooved Conduit End Fitting

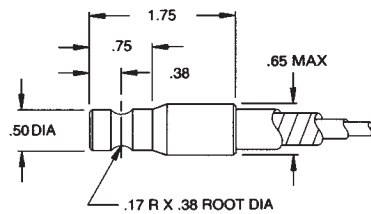

PART NO. 062

Clip-Lock Conduit End Fitting

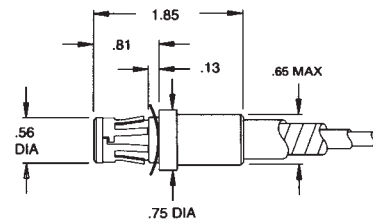

PART NO. 065
 For .125 and .187 thick material.

Grooved Conduit End Fitting

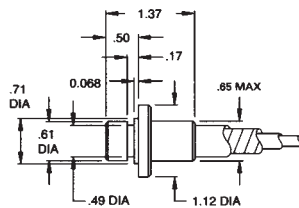

PART NO. 026

48° Clip-Lock Conduit End Fitting

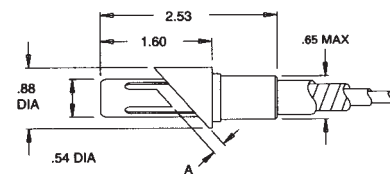

| PART NO. | A |
|----------|-----|
| 066 | .13 |
| 067 | .20 |

Grooved Conduit End Fitting

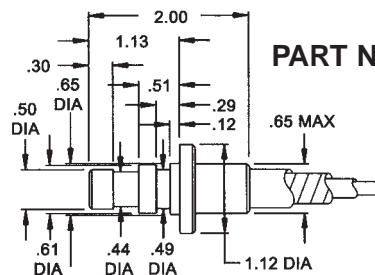

PART NO. 027

Pull-Only Brake Cable Specifications

| Threaded End Fitting | A | B | C |
|----------------------|---------|------|------|
| TE504 | 5/16-24 | 3.62 | 2.22 |
| TE504-006 | 5/16-24 | 2.00 | .97 |
| TE504-007 | 5/16-24 | 6.00 | 4.60 |
| TE506 | 3/8-24 | 2.62 | 1.47 |
| TE523-001 | 1/4-28 | 3.62 | 2.47 |

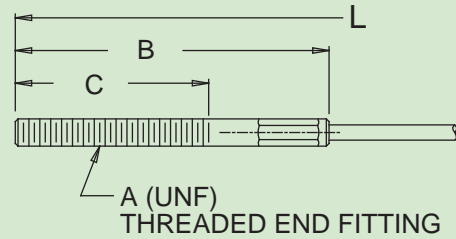

Cable Stop

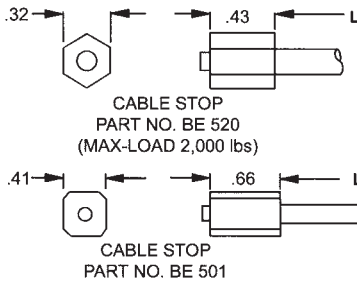

Ball End

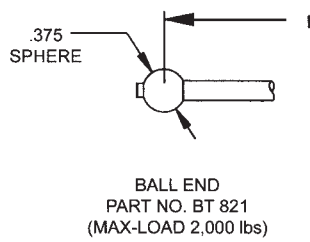

Eye End

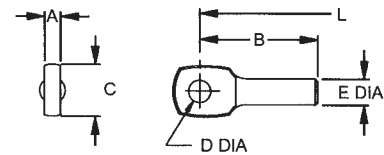

| PART NO. | A | B | C | D | E |
|-------------|------|------|-----|------|------|
| 157-047-000 | .235 | 1.81 | .75 | .323 | .375 |
| EE9158 | .240 | 1.60 | .75 | .500 | .437 |

Strap Clevis Part Numbers (For both 1500 and 3000 brake)

| Open Strap Clevis | A | B | D | F | G | H |
|---------------------|------|------|-----|------|-----|------|
| CS540 | - | 1.62 | .31 | .62 | .43 | .266 |
| CS540-001 | - | 1.62 | .31 | .62 | .51 | .266 |
| CS540-006 | - | 2.50 | .38 | .75 | .57 | .386 |
| CS540-007 | - | 2.50 | .31 | .62 | .51 | .266 |
| CS541 | - | 1.94 | .38 | .75 | .51 | .266 |
| CS541-003 | - | 1.94 | .38 | .75 | .51 | .323 |
| CS541-005 | - | 2.00 | .38 | .75 | .51 | .266 |
| CS541-007 | - | 2.50 | .38 | .75 | .51 | .266 |
| CS541-008 | - | 2.50 | .38 | .75 | .51 | .323 |
| CS542* | - | 1.08 | .50 | 1.00 | .58 | .323 |
| Step Strap Clevis | A | B | C | D | F | H |
| CS550 | .31 | 1.56 | .19 | .31 | .62 | .266 |
| CS550-001 | .31 | 1.56 | .19 | .38 | .62 | .266 |
| CS550-002 | .31 | 1.56 | .19 | .31 | .62 | .316 |
| CS550-004 | .31 | 1.56 | .19 | .25 | .62 | .266 |
| CS551 | .38 | 1.75 | .25 | .31 | .62 | .266 |
| CS551-001 | .38 | 1.75 | .25 | .38 | .62 | .266 |
| CS551-002 | .75 | 2.38 | .25 | .31 | .62 | .316 |
| CS551-003 | .38 | 1.50 | .25 | .25 | .62 | .266 |
| CS552 | .31 | 2.38 | .25 | .31 | .75 | .266 |
| CS552-001 | .31 | 2.38 | .25 | .38 | .75 | .266 |
| CS552-003 | .38 | 2.38 | .25 | .43 | .75 | .316 |
| CS552-004 | .38 | 2.38 | .25 | .31 | .75 | .316 |
| CS553 | .50 | 1.88 | .19 | .38 | .75 | .266 |
| Closed Strap Clevis | A | B | C | D | F | H |
| CS562 | .31 | 1.62 | - | .31 | .62 | .316 |
| CS563 | .28 | 1.75 | - | .31 | .62 | .316 |
| CS564 | 1.00 | 2.38 | - | .38 | .75 | .316 |

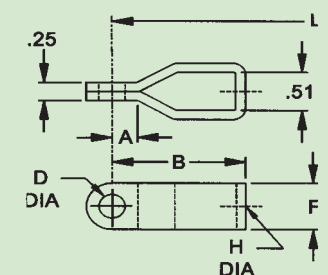
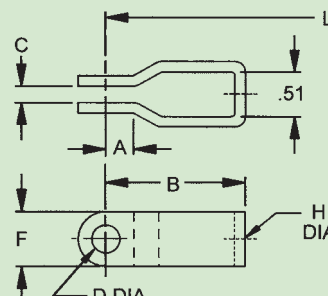
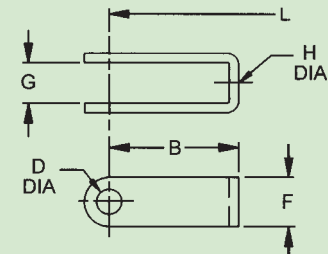

*use with 5/16 threaded end rod with nuts only

All line art dimensions are represented in inches

Pull-Only Brake Cables

3000 lb Series

Ultimate Load: 3000 lb
 Minimum Bend Radius: 7"
 See page E1 for ordering procedure.
 See page E2 for strap clevis part numbers.

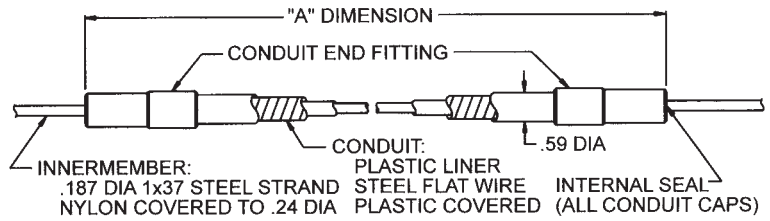

Threaded Conduit End Fitting Grooved Conduit End Fitting Grooved Conduit End Fitting

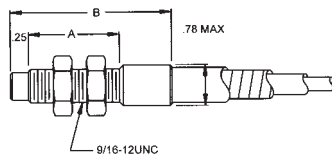

| PART NO. | A | B |
|----------|-----|-----|
| 070 | 1.4 | 2.7 |
| 071 | 2.1 | 3.3 |

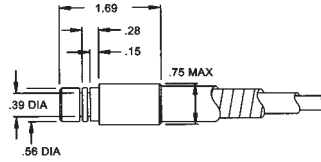

| PART NO. | Use E-Clip |
|----------|-------------|
| 074 | 175-435-025 |

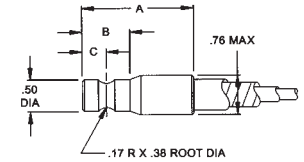

| PART NO. | A | B | C |
|----------|------|-----|-----|
| 072 | 1.75 | .75 | .38 |
| 073 | 1.88 | .88 | .44 |

Clip-Lock Conduit End Fitting

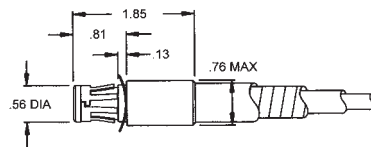

PART NO. 075
 For .125 and .187 thick material.

48° Clip-Lock Conduit End Fitting

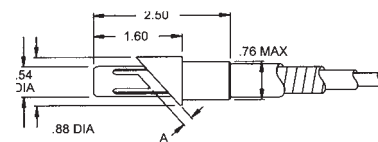

| PART NO. | A |
|----------|-----|
| 076 | .33 |
| 077 | .20 |

Ball End

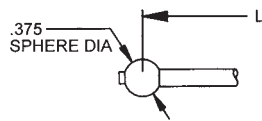

PART NO. BT 822
 (2000 lb max load)

Cable Stop

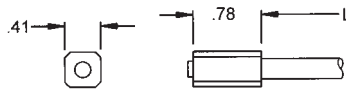

PART NO. BE 502

Eye End

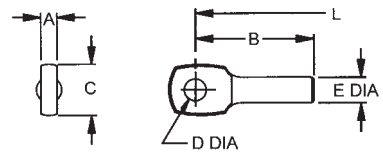

| PART NO. | A | B | C | D | E |
|-------------|------|------|-----|------|------|
| 157-047-002 | .235 | 1.81 | .75 | .323 | .375 |

Threaded End Fitting

| | A | B | C |
|---------|---------|------|------|
| TE505 | 3/8-24 | 2.95 | 2.00 |
| TE505-1 | 3/8-24 | 1.88 | 1.00 |
| TE508 | 3/8-24 | 2.62 | 1.50 |
| TE509-1 | 3/8-24 | 4.95 | 3.75 |
| TE510-1 | 5/16-24 | 2.50 | 1.50 |
| TE510-2 | 5/16-24 | 3.62 | 2.24 |
| TE510-4 | 5/16-24 | 4.00 | 3.00 |
| TE510-5 | 1/4-28 | 3.62 | 2.50 |
| TE510-6 | 5/16-24 | 2.12 | 1.00 |
| TE510-7 | 5/16-24 | 2.88 | 1.50 |
| TE510-8 | 5/16-24 | 5.60 | 4.47 |
| TE510-9 | 5/16-24 | 3.00 | 1.91 |
| TE605 | 3/8-24 | 6.00 | 5.00 |

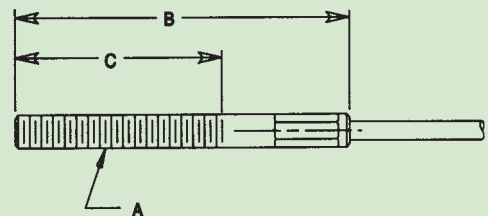

Cablecraft Locking Brake Levers

- Adjustable, over-center locking brake levers. No ratcheting, only “ON” (over-center) or “OFF” positions.
- Easy adjusting knob allows 1.6” of cable to increase or decrease cable tension as needed to compensate for wear or load conditions.
- Load link is fabricated of 4130 alloy steel. Normal operation capacity 1000 lb.
- Ultimate load capacity 3000 lb (non-recurring static load).
- Unless otherwise specified, levers include connecting hardware. Supplied with all required clevis pins, washers and cotter pins needed to attach cable. Bolts to connect lever to vehicle are not provided.

Optional Features

Tamper resistant knob (adjustment limited by Allen-head set-screw).

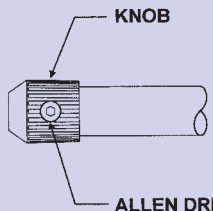

ALLEN DRIVE LOCKING SCREW

Weather resistant safety switch kit (normally closed) for extra security. Part No. B862

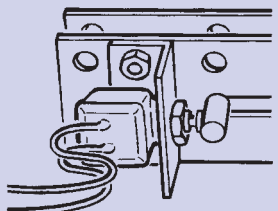

Specifications

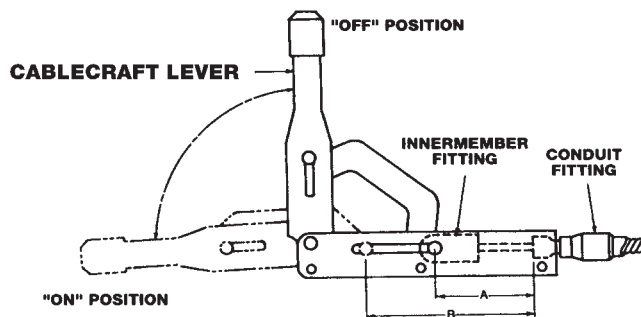

| Cablecraft® Lever | Innertype Fitting | | Conduit Fitting | | Dimension | | |
|----------------------|-------------------|-------------|-----------------|---------|-----------|--------|--------|
| | 3000 lb | 1500 lb | 3000 lb | 1500 lb | A | B min. | B max. |
| 165-508-008 | CS550-2 | CS550 | 073 | - | 3.23 | 3.87 | 5.47 |
| | | | 072 | 062 | 3.36 | 4.00 | 5.60 |
| 165-508-011 | CS550-2 | CS550 | 072 | 062 | 2.71 | 3.35 | 4.95 |
| 165-508-023 | 157-047-002 | 157-047-000 | 072 | 062 | 2.38 | 3.02 | 4.62 |
| 165-508-028 | CS550-2 | CS550 | 075 | 065 | 3.14 | 3.78 | 5.35 |
| 165-508-010 | CS550-2 | CS550 | 073 | - | 1.70 | 2.34 | 3.94 |
| | | | 072 | 062 | 1.83 | 2.47 | 4.07 |
| 165-508-009 | CS550-2 | CS550 | - | - | - | - | - |
| 165-508-078 | CS550-2 | CS550 | 073 | - | 1.70 | 2.34 | 3.94 |
| | | | 072 | 062 | 1.83 | 2.47 | 4.07 |
| 165-508-013 | 157-047-002 | 157-047-000 | 073 | - | 2.27 | 2.91 | 4.51 |
| | | | 072 | 062 | 2.40 | 3.04 | 4.69 |

- Dimension A is with the lever in full “OFF” position. Use dimension A in calculating cable length.
- Dimension B minimum is with the lever in full “ON” position and adjusted for minimum (CCW) travel. Use dimension B minimum during installation and initial adjustment. Turn knob (CW) to add travel and increase brake pressure setting.
- Dimension B maximum is with the lever in full “ON” position and adjusted for maximum (CW) travel.

Locking Brake Levers

Side Mount 165-508-008

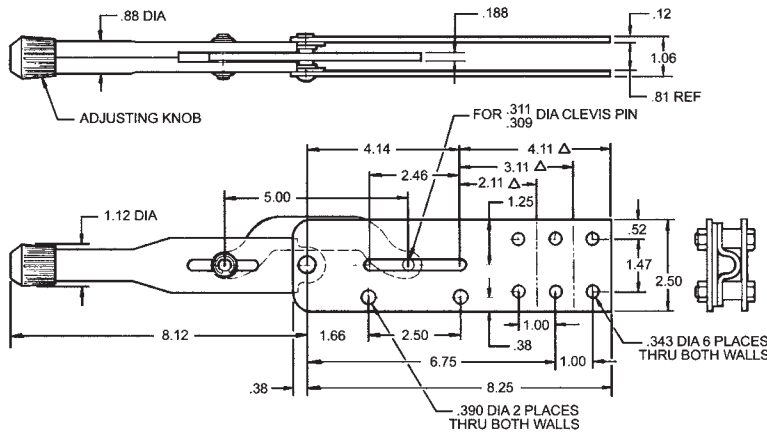

2.5 inches (64mm) wide side plates; one cable, with three alternate sets of cable clamp holes. For cowl, instrument panel, seat riser or frame installation.

Kit B815 — supplied with the following hardware:

- Clevis Pin
- Cotter Pin
- Washer
- Mounting Spacers (2)
- Cable Clamp
- Clamp Base
- Clamp Spacers (2)

Side Mount 165-508-009

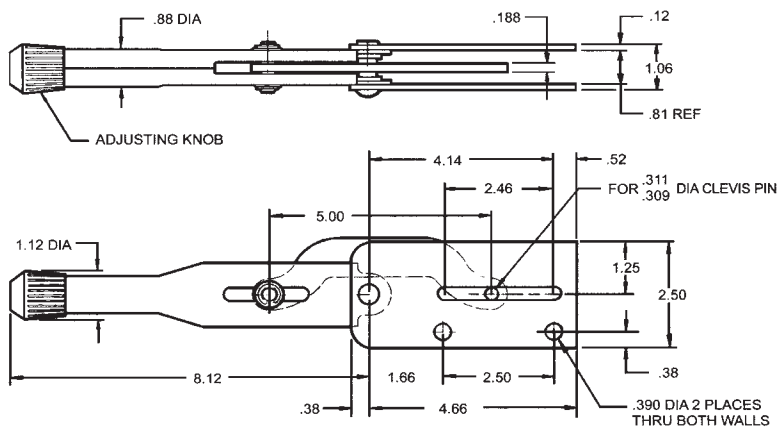

2.5 inches (64mm) wide side plates; one cable. For cowl, instrument panel, seat riser or frame installation. No cable support.

Kit B816 — supplied with the following hardware:

- Clevis Pin
- Cotter Pin
- Washer
- Mounting Spacers (2)

Side Mount 165-508-011

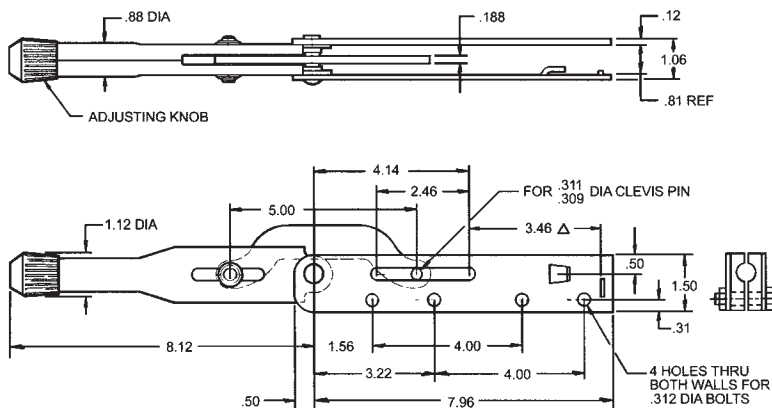

1.5 inches (38mm) wide side plates; one cable. For cowl, instrument panel, seat riser or frame installation.

Kit B834 — supplied with the following hardware:

- Clevis Pin
- Cotter Pin
- Washer
- Mounting Spacers (2)
- Cable Clamp

Locking Brake Levers

Side Mount 165-508-028

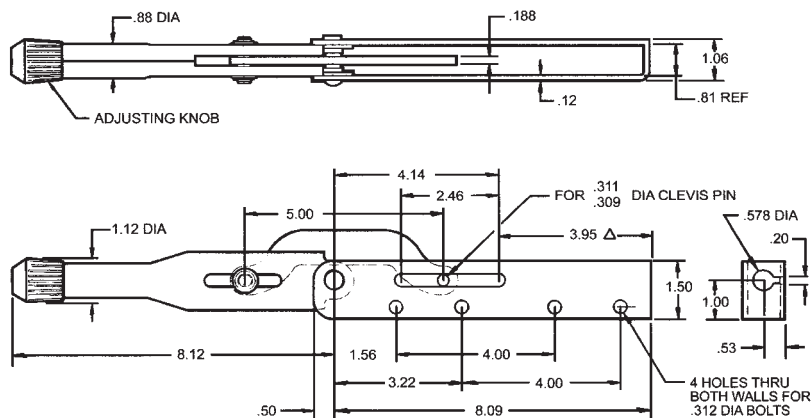

1.5 inches wide side plates; one cable. For cowl, instrument panel, seat riser or frame installation.

Kit B837 — supplied with the following hardware:

- Clevis Pin
- Cotter Pin
- Washer
- Mounting Spacers (2)
- Cable Clamp
- Clamp Spacers (2)

Flange Mount-Rigid 165-508-010

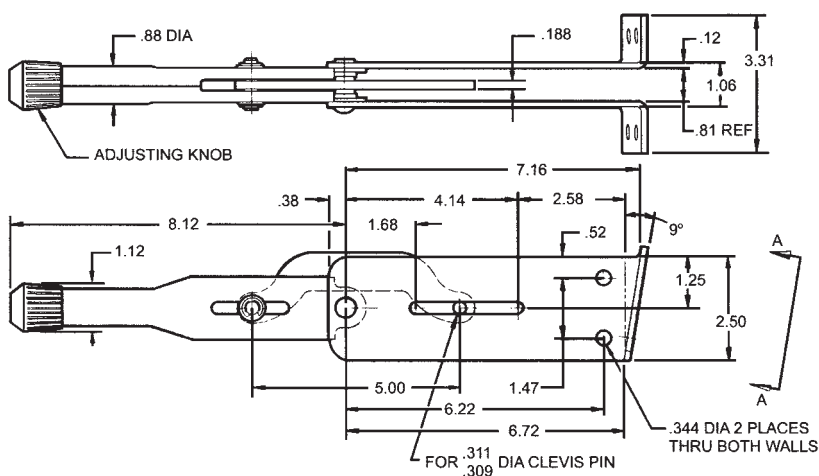

2.5 inches (64mm) wide side plates; one cable. For bulk-head floor or island (doghouse) installation. The rigid frame maintains alignment of clevis pin guide slots for improved life of both the pin and side plates.

Kit B817 — supplied with the following hardware:

- Clevis Pin
- Cotter Pin
- Washer
- Cable Clamp
- Clamp Base
- 5/16-24 Bolts (2) Nuts(2)

Flange Mount 165-508-078

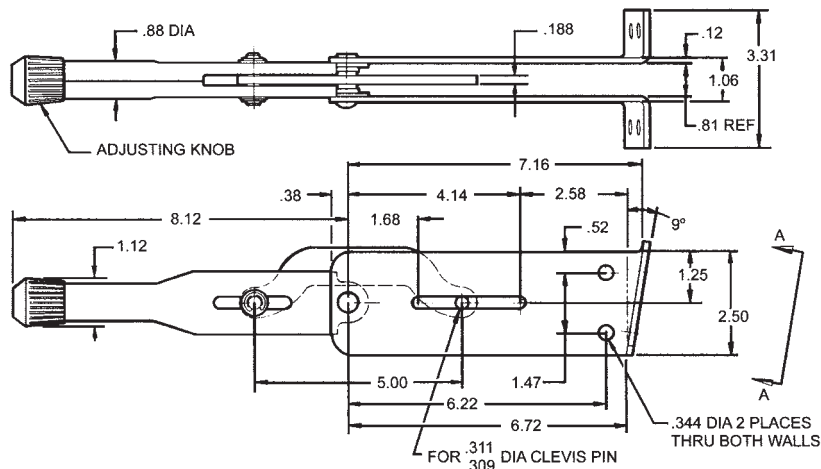

2.5 inches (64mm) wide side plates; one cable. For bulk-head floor or island (doghouse) installation. Angle wing flange mounting.

Kit B838 — supplied with the following hardware:

- Clevis Pin
- Cotter Pin
- Washer
- Cable Clamp
- Clamp Base
- 5/16-24 Bolts (2) Nuts(2)

Locking Brake Levers

Side Mount 165-508-013

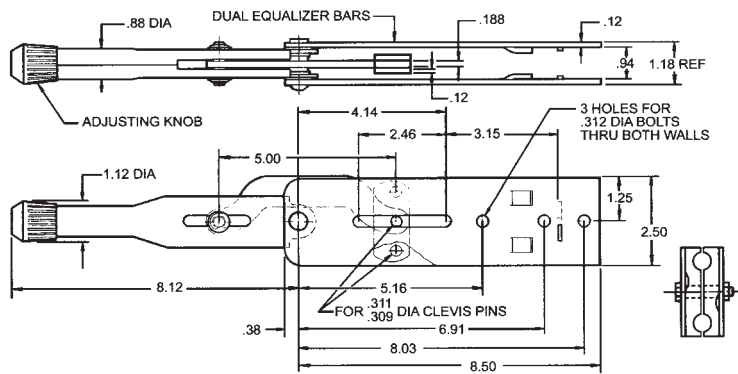

2.5 inches (64mm) wide side plates; two cables. For cowl, instrument panel, seat riser or frame installation. NOTE: When considering load requirements, the load on the lever assembly will be the sum of the load in each cable.

Kit B835 — supplied with the following hardware:

- Clevis Pins (2)
- Cotter Pins (2)
- Washers (2)
- Mounting Spacers (2)
- Cable Clamps

Flange Mount-Rigid 165-508-023

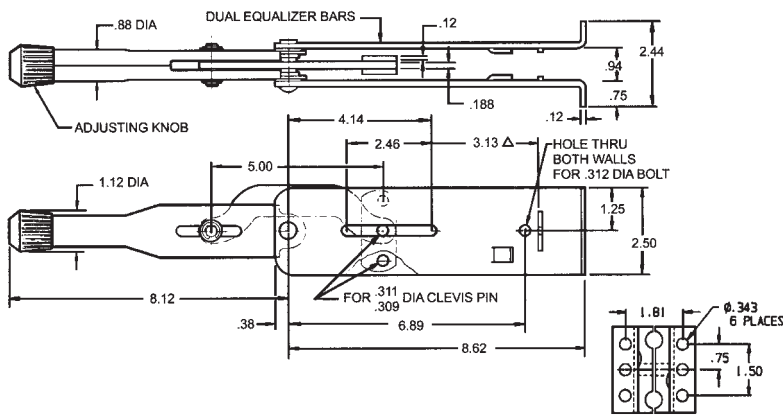

2.5 inches (64mm) wide side plates; two cables. For bulkhead, floor or island (doghouse) installation. NOTE: When considering load requirements, the load on the lever assembly will be the sum of the load in each cable. Wing flange mounting.

Kit B835 — supplied with the following hardware:

- Clevis Pins (2)
- Cotter Pins (2)
- Washers (2)
- Mounting Spacers (2)
- Cable Clamps

Accessories

Spacers

| Part No. | "A" |
|----------|------|
| DG 604-1 | 0.81 |
| DG 604-2 | 0.57 |
| DG 609 | 0.53 |

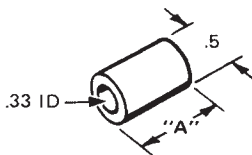

Clamp and Base

C908 kit includes:
1 ea. DC 179-1 base
1 ea. DC 180 clamp

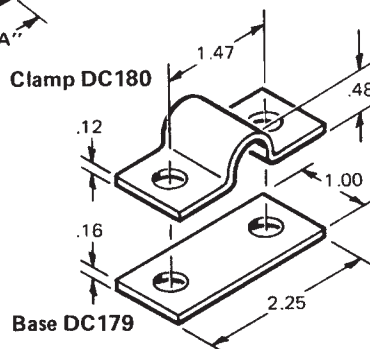

Cable Clamps

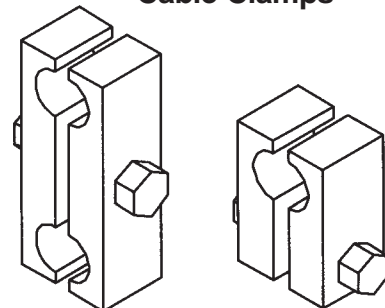

190-852-001
Double

190-852-002
Single

Pull-Only Clutch Cables

High quality replacements for most cab-over engine vehicles and other similar applications. Built to specifications by your local cable assembler.

Generic clutch replacement cables HD conduit, special clutch innermember
 Part No. CA235-A-L (5/16-24 end rods) Part No. CA236-A-L (3/8-24 end rods)

Order Code: A = Conduit length; L = Length overall

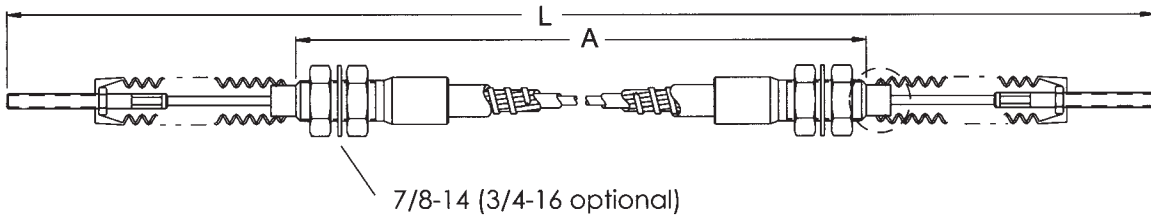

General Motors® style clutch cable, 1500lb brake conduit and innermember
 Part No. CA270-XXX (XXX = Dash number, see table below)

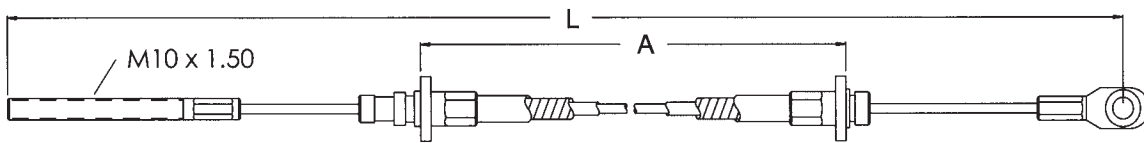

CA270-XXX

| Dash No. | GM® Part No. | A | L |
|----------|--------------|-------|-------|
| -010 | 15520115 | 47.56 | 76.69 |
| -009 | 15518380 | 43.31 | 71.65 |
| -008 | 15518379 | 51.18 | 79.53 |
| -007 | 15518378 | 44.88 | 74.21 |
| -006 | 15518377 | 37.60 | 66.93 |
| -005 | 15507983 | 44.55 | 69.01 |
| -004 | 15507982 | 26.00 | 52.75 |
| -003 | 15507981 | 45.27 | 72.91 |
| -002 | 15507980 | 44.49 | 72.95 |
| -001 | 15507979 | 40.94 | 68.07 |

GM is a registered trademark of General Motors.

General Motors® style clutch cable, 1500lb brake conduit and innermember
 Part No. CA271-A-L (A = Conduit length; L = Length overall)

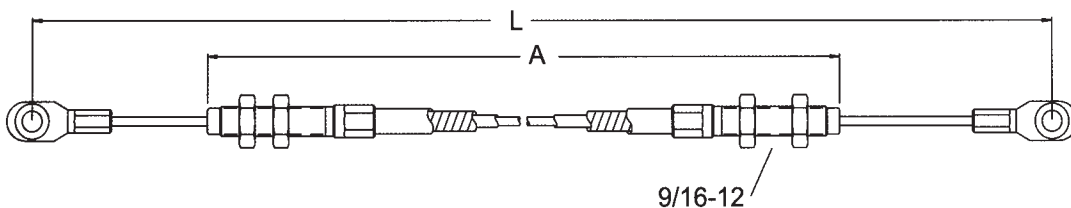

All line art dimensions are represented in inches

Pull-Only Clutch Cables

Mack Truck® style clutch cable, HD conduit and special clutch innermember
Part No. CA312-A-L (A = Conduit length; L = Length overall; see table)

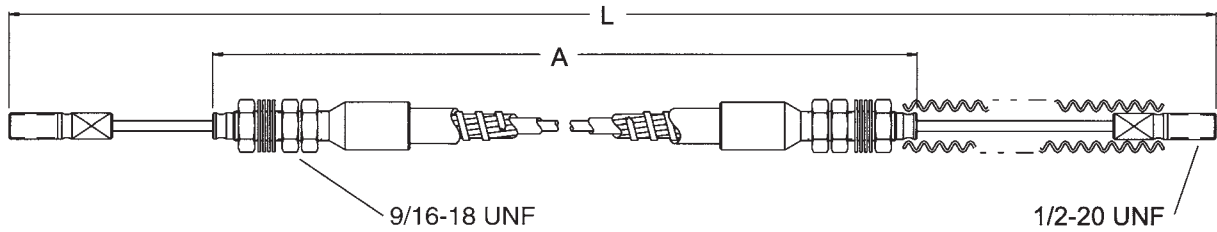

CA312-A-L

| Part No. | A | L |
|-------------------|-------|-------|
| CA312-34.6-42.0 | 34.6 | 42.0 |
| CA312-55.6-63.0 | 55.6 | 63.0 |
| CA312-79.6-87.0 | 79.6 | 87.0 |
| CA312-85.6-93.0 | 85.6 | 93.0 |
| CA312-91.6-99.0 | 91.6 | 99.0 |
| CA312-102.6-110.0 | 102.6 | 110.0 |
| CA312-127.6-135.0 | 127.6 | 135.0 |
| CA312-25.6-36.0 | 25.6 | 36.0 |
| CA312-34.6-45.0 | 34.6 | 45.0 |
| CA312-43.6-54.0 | 43.6 | 54.0 |
| CA312-55.6-66.0 | 55.5 | 66.0 |
| CA312-67.6-78.0 | 67.6 | 78.0 |
| CA312-79.6-90.0 | 79.6 | 90.0 |
| CA312-85.6-96.0 | 85.6 | 96.0 |
| CA312-91.6-102.0 | 91.6 | 102.0 |
| CA312-103.6-114.0 | 103.6 | 114.0 |
| CA312-118.6-129.0 | 118.6 | 129.0 |
| CA312-29.6-40.0 | 29.6 | 40.0 |
| CA312-95.6-106.0 | 95.6 | 106.0 |
| CA312-107.6-118.0 | 107.6 | 118.0 |

IHC Transtar® style clutch cable, HD conduit and special clutch innermember
Part No. CA327-L (L = Length overall)

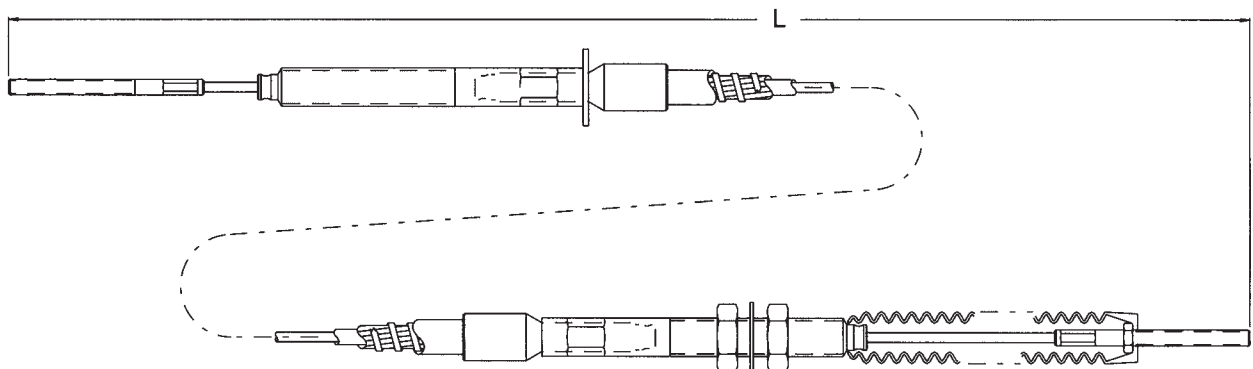

All line art dimensions are represented in inches

Pull-Only Clutch Cables

See “Push-Pull Cable Specifications” (page 9) for mid-travel dimensions.
 HD conduit, brake/clutch innermember 500 lb pull-only operating load.

Order Code: T = Travel 2”- 6”; L = Length overall

Part No. A183-400-T-L (5/16-24 end rods MD) Grooved-Grooved
 Part No. A183-111-T-L (3/8-24 end rods HD) Grooved-Grooved

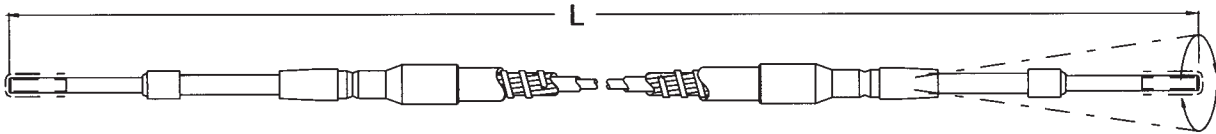

Part No. A183-401-T-L (5/16-24 end rods MD) Grooved-Threaded 11/16-16
 Part No. A183-110-T-L (3/8-24 end rods HD) Grooved-Threaded 7/8-14

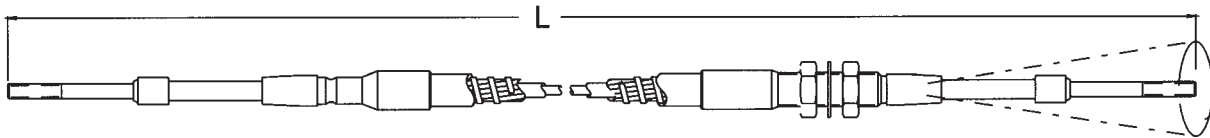

Part No. A183-402-T-L (5/16-24 end rods MD) Threaded-Threaded (both ends 11/16-16)
 Part No. A183-104-T-L (3/8-24 end rods HD) Threaded-Threaded (both ends 7/8-14)

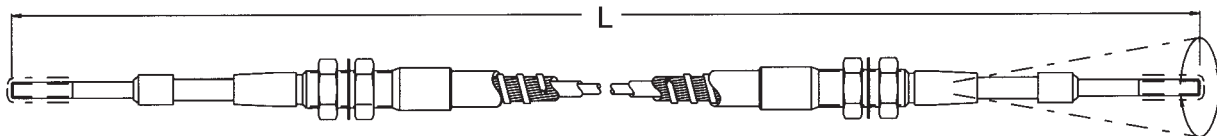

All line art dimensions are represented in inches

Throttle/Accelerator Cables (Pull-Only)

Part No. A156-637-L (1/4-28 end rods) Grooved-Grooved
Part No. A156-657-L (10-32 end rods) Grooved-Grooved

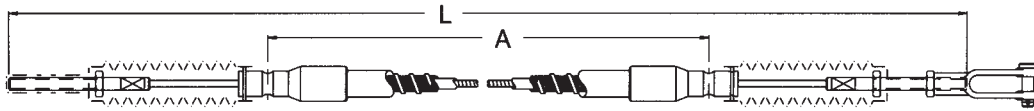

"A" dimension fixed in relation to "L" dimension. Bellows on both ends.

Part No. A156-638-L (1/4-28 end rods) Threaded-Grooved
Part No. A156-658-L (10-32 end rods) Threaded-Grooved

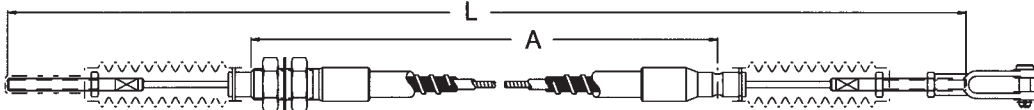

Part No. A156-679-L (1/4-28 end rods) Threaded-Threaded
Part No. A156-680-L (10-32 end rods) Threaded-Threaded

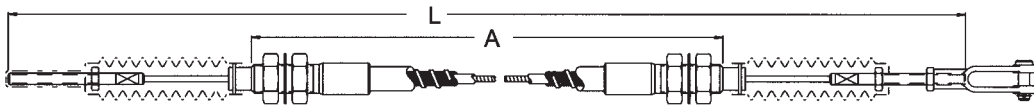

Part No. CA305-TT-A-L (1/4-28 end rods) Threaded-Threaded
Part No. CA306-TT-A-L (10-32 end rods) Threaded-Threaded

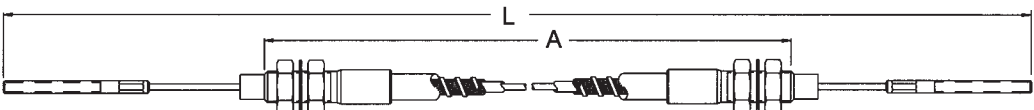

"A" dimension variable in relation to "L" dimension. Bellows optional.

Part No. CA305-TG-A-L (1/4-28 end rods) Threaded-Grooved
Part No. CA306-TG-A-L (10-32 end rods) Threaded-Grooved

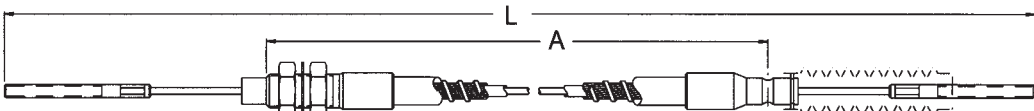

Part No. CA305-GG-A-L (1/4-28 end rods) Grooved-Grooved
Part No. CA306-GG-A-L (10-32 end rods) Grooved-Grooved

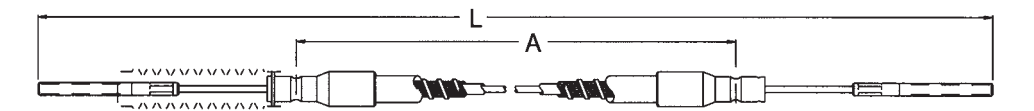

Part No. CA307-A-L (1/4-28 end rods) Special

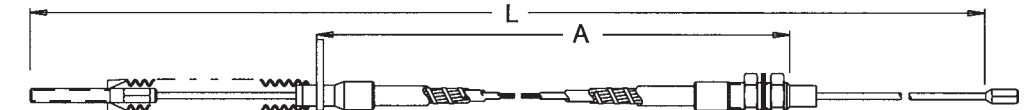

All line art dimensions are represented in inches

Medium-Duty Throttle

Applications:

- Farm machinery
- Heavy machinery
- Landscaping equipment
- Construction equipment
- Warehouse equipment

Features:

- Steel construction
- Rear or front throttle connection
- Multiple base bolt patterns
- Spring returned pedal
- Travel: 3.00" maximum
- -25°F —160°F temperature range (-14°C — 90°C)
- Coated sheet metal components
- Embossed pedal surface reduces slippage

Material:

- Coated sheet metal
- Plastic bushings
- Plastic boot plated steel hardware

Fast and Economical Installation

A throttle cable simplifies the installation, providing a complete system to suit many applications.

The pedal tower mechanism is designed to be dropped through the floor and secured. Cable attachment can then be quickly and easily completed.



Medium-Duty Pedal CH530

For use with single pull-only throttle (gas) cables.

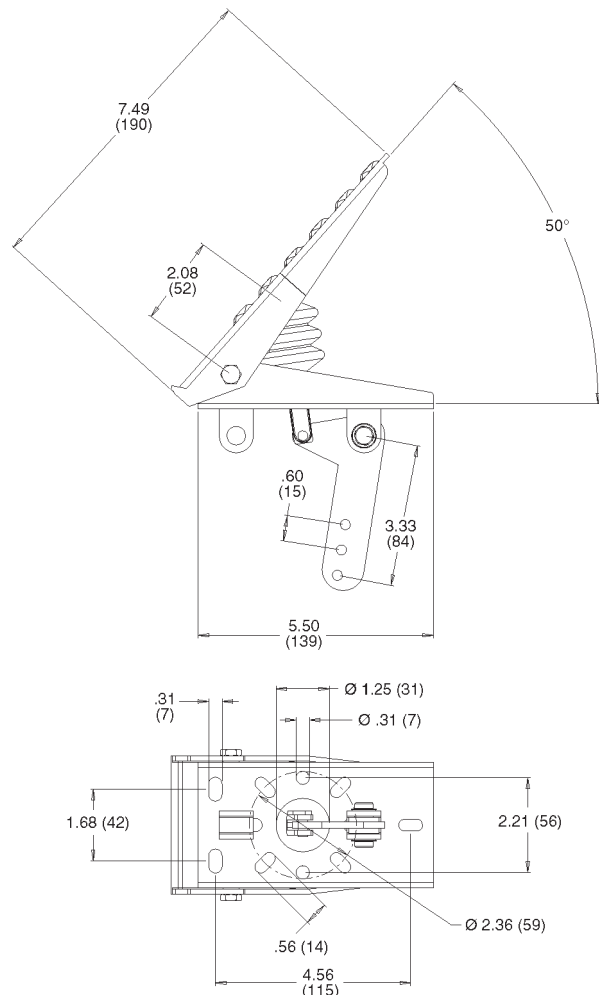

All line art dimensions are represented as follows: in (mm)

Heavy-Duty Throttle

Applications:

- Medium & heavy-duty trucks
- Construction equipment
- Farm equipment
- Buses

Features:

- Die cast & steel components
- Multiple base bolt patterns
- Spring returned pedal
- Adjustable pedal angle
- Throttle cable exit is adjustable
- Travel: 2.00" maximum
- -25°F — 160°F temperature range (-14°C — 90°C)
- Corrosion-resistant die cast components, plated steel hardware and plastic bushings

Material:

- Coated sheet metal
- Plastic bushings
- Plastic boot plated steel hardware

Suggested End Fittings:

- Clevis and pin, or end fitting with right angle bend



Standard Pedal 165-574-002

For use with two pull-only accelerator cables.

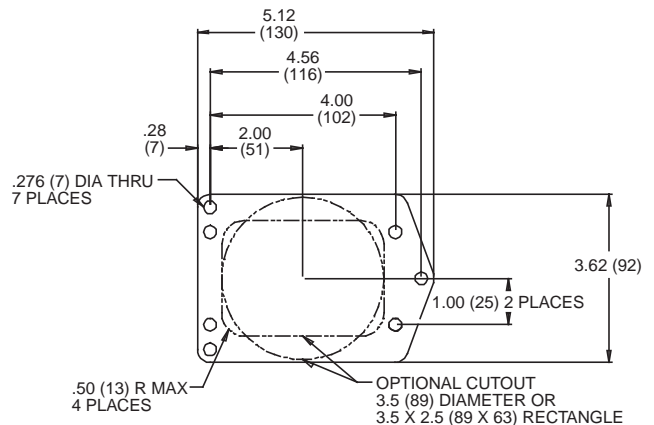
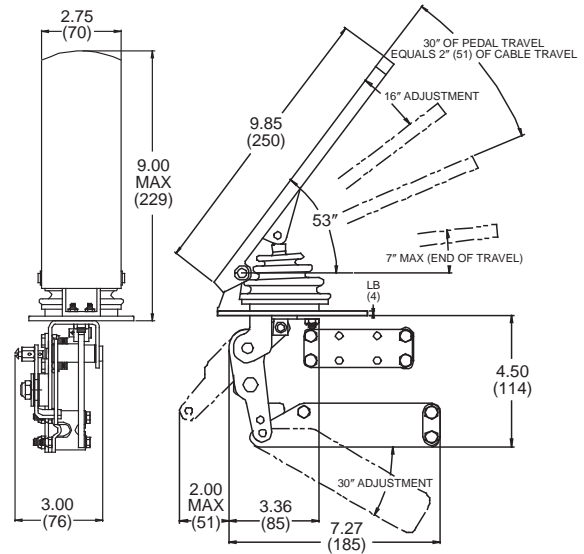

Fast and Economical Installation

A throttle cable simplifies the installation, providing a complete system to suit many applications.

The pedal tower mechanism is designed to be dropped through the floor and secured. Cable attachment can then be quickly and easily completed.

All line art dimensions are represented as follows: in (mm)

Remote Valve Control Specialty Cables

Used to operate hydraulic valves. Ideal for wet-line kits, relocating valves, or vehicle modifications. Mounting kits available for most popular “spool” type valves.

Part No. A17X-334 Utility Part No. A31X-334 EXT

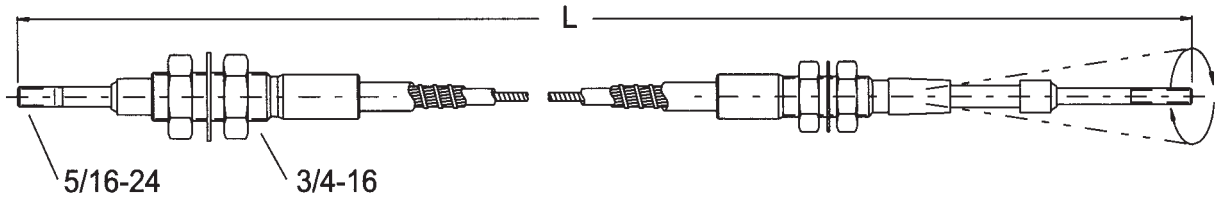

Part No. A17X-335 Utility Part No. A31X-335 EXT

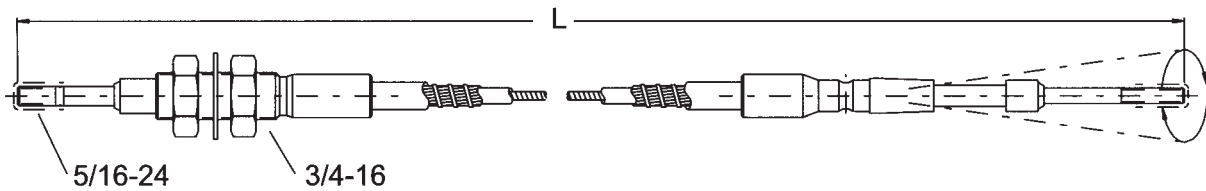

Part No. A17X-342 Utility

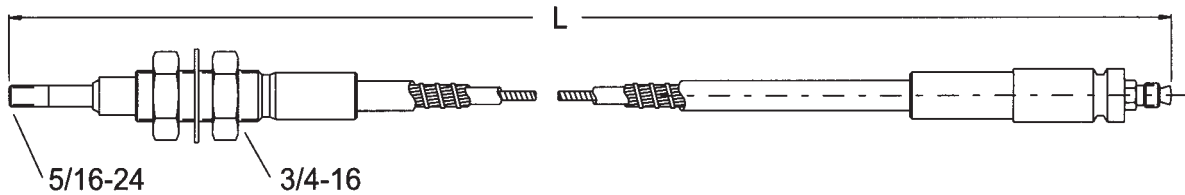

Part No. A17X-351 Utility

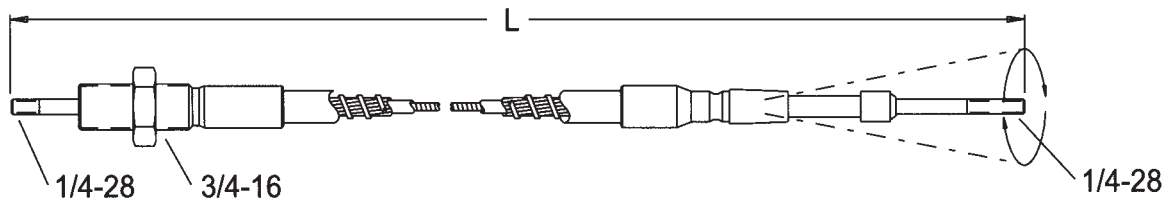

Part No. A17X-352 Utility

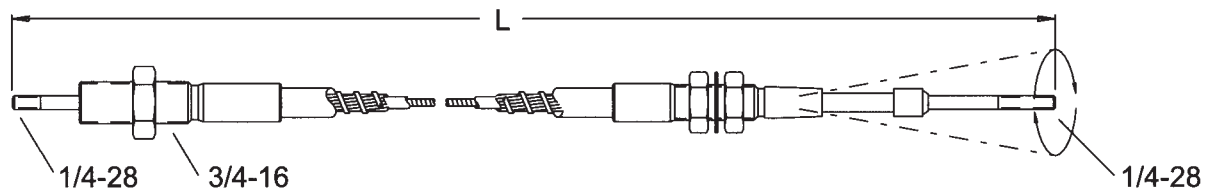

All line art dimensions are represented in inches

Remote Valve Control Specialty Cables (continued)

Part No. CA260 Utility Part No. CA261 EXT

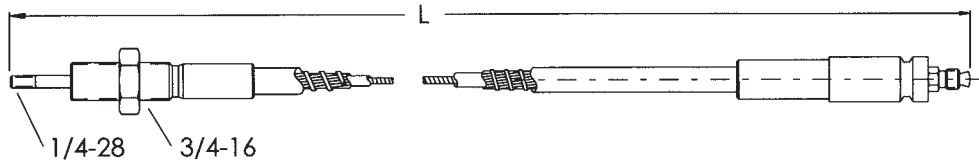

Part No. CA22XG

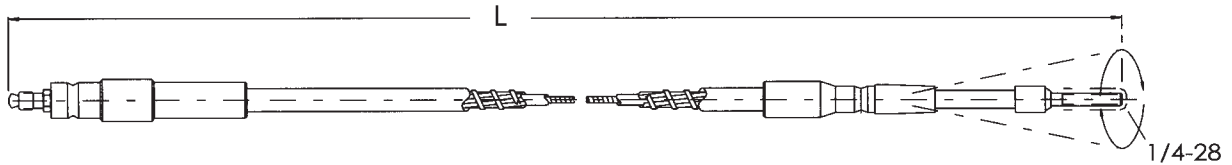

Part No. CA22XT

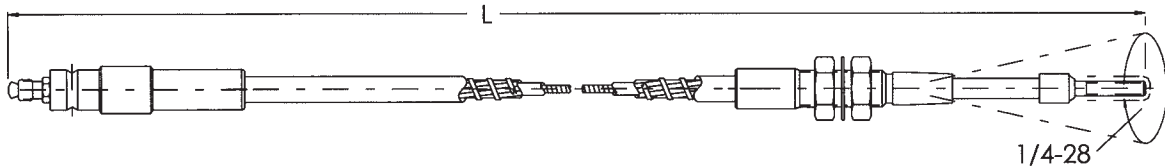

Cable Mounting Kits

Cablecraft® mounting kits fit most popular valves. HUSCO mounting kit shown in diagram.



Kit includes:
Adapter bracket, clevis,
clevis pin and hardware

| Part No. | For Use On: |
|-------------|---|
| 185-101-001 | Comm. Shearing 505 |
| 185-101-002 | Comm. Shearing D50 |
| 185-101-003 | Comm. Shearing A35 |
| 185-101-004 | Comm. Shearing A20 |
| 185-101-005 | Comm. Shearing VA20 |
| 185-101-006 | HUSCO 6000 |
| 185-101-007 | HUSCO 7120 |
| 185-101-008 | Gresen V20, V31P, V42, CP, CT, CPT, CS, 25P, 25PK |

All line art dimensions are represented in inches

HUSCO 5000 Valve Control Cables

These cables include cable mounting bracket, jam nuts and clevis pin.

Part No. A17X-341

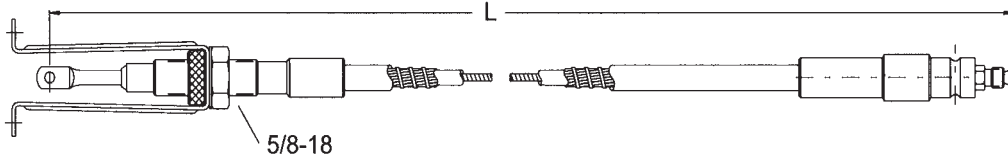

Part No. A17XX-362 Utility Part No. A31X-362 EXT

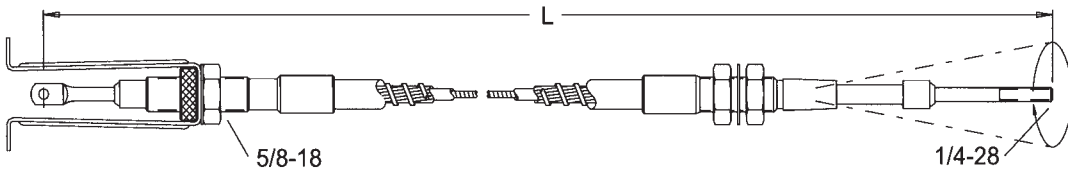

Part No. A17XX-363 Utility Part No. A31X-363 EXT

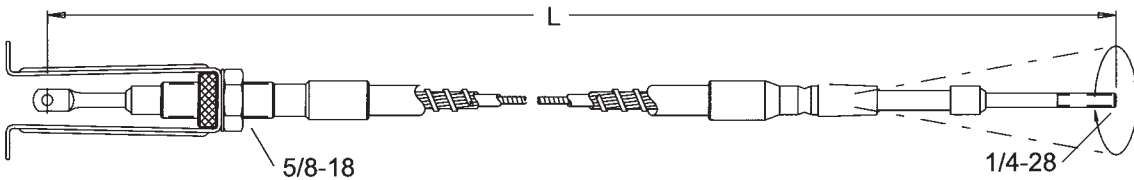

Single Axis Levers

Single Axis Valve Lever
#165-042-001



Cablecraft®
HD Lever
#165-041-002



All line art dimensions are represented in inches

Modulator Specialty Cables

Modulator and cable interconnect Allison® automatic transmission with engine fuel control. Modulator can be set to either “push” or “pull” to operate.

Cablecraft® Modulator Unit and Cable

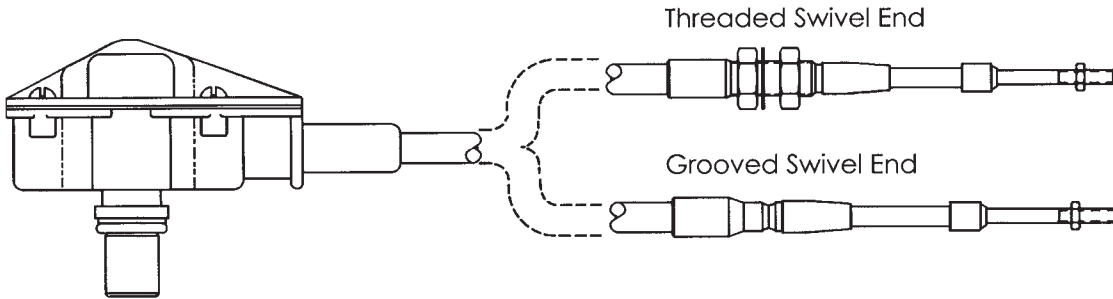

| Modulator Unit with Cable | | | |
|---------------------------|-----------------|-----------------|---------------------------|
| Cable Output End | Pull To Operate | Push To Operate | Replacement Modulator Box |
| Grooved Mount | | | |
| 173 Utility | CA 343-3-001-L | CA 343-3-002-L | Part No. 165-900 |
| 174 Utility | CA 343-4-001-L | CA 343-4-002-L | |
| Threaded Mount | | | |
| 173 Utility | CA 341-3-001-L | CA 341-3-002-L | Part No. AC-310 |
| 174 Utility | CA 341-4-001-L | CA 341-4-002-L | |

Replacement Cables for Cablecraft Modulator

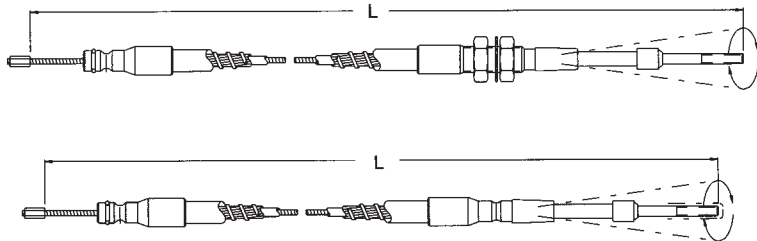

| Cable Only Part No. | Cable Output End |
|---------------------|------------------|
| Threaded Mount | |
| CA 341-3 | 173 Utility |
| CA 341-4 | 174 Utility |
| Grooved Mount | |
| CA 343-3 | 173 Utility |
| CA 343-4 | 174 Utility |

Replacement Cables for other USA Manufactured Modulator

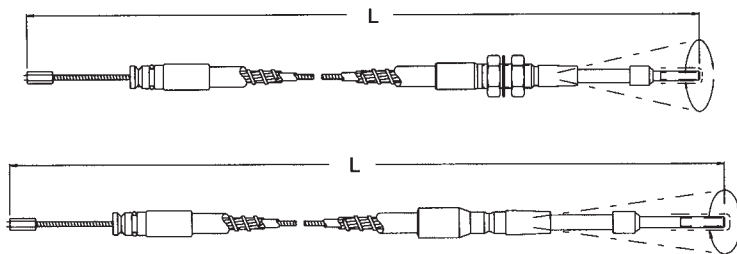

| Cable Only Part No. | Cable Output End |
|---------------------|------------------|
| Threaded Mount | |
| CA 213 T-L | 173 Utility |
| CA 214 T-L | 174 Utility |
| Grooved Mount | |
| CA 213 G-L | 173 Utility |
| CA 214 G-L | 174 Utility |

Automotive Shift Specialty Cables

Replacements for popular brand shift cables.

Order Code: X = 3 for Carbon Steel, X = 4 for Stainless Steel; L = Length

B&M® Shift Part No. CA248-X-L

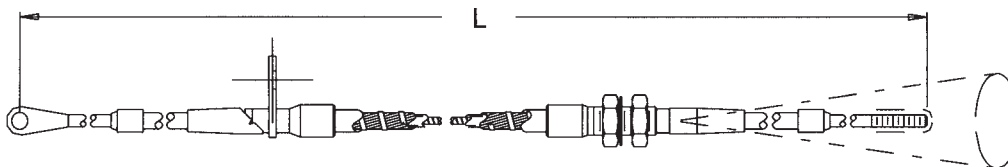

Dodge® Motor Home Part No. CA249-X-L

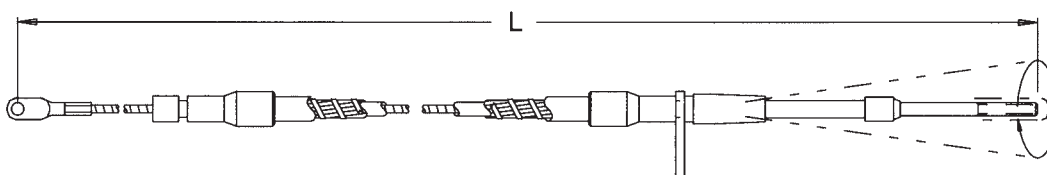

Hurst® Shift Part No. CA273-X-L

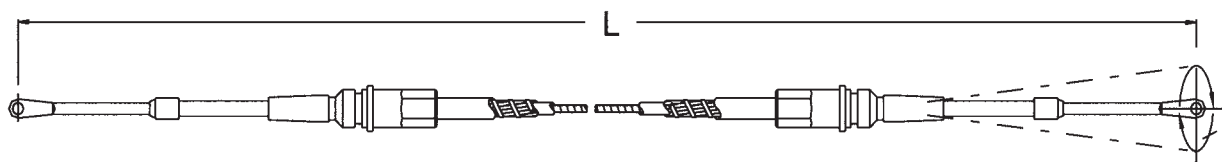

Hurst® Shift Part No. CA274-X-L

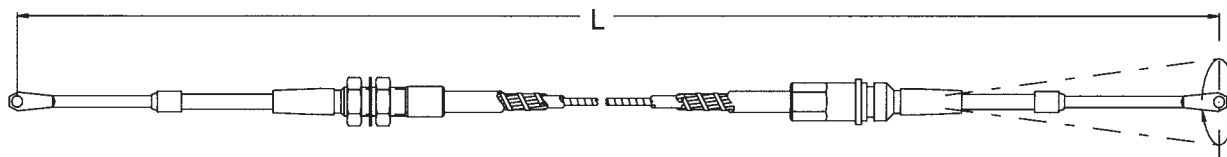

Hurst® Shift Part No. CA275-X-L

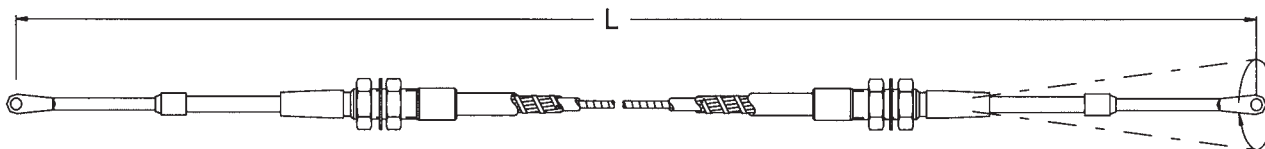

MTS Cables (Manual Transmission System)

Replacements for Cablecraft's® cable operated manual transmission shift system.

Order Code: X = 3 for stainless end rods with Model 6 seals

X = 4 for stainless support tubes and end rods with Model 6 seals

L = Length

Part No. A31X-105-L Grooved-Grooved

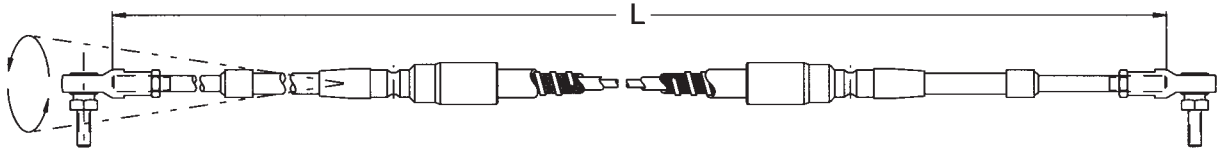

Part No. A31X-106-L Same as -105 but with an umbrella seal

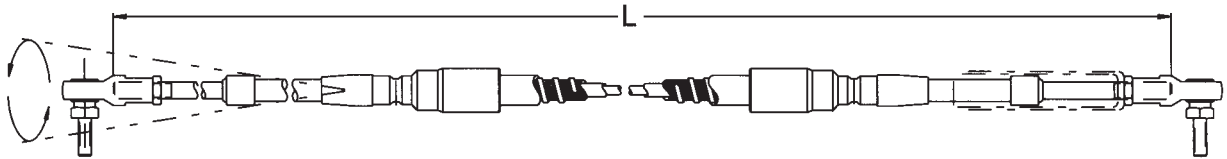

Part No. A31X-113-L Grooved-Threaded

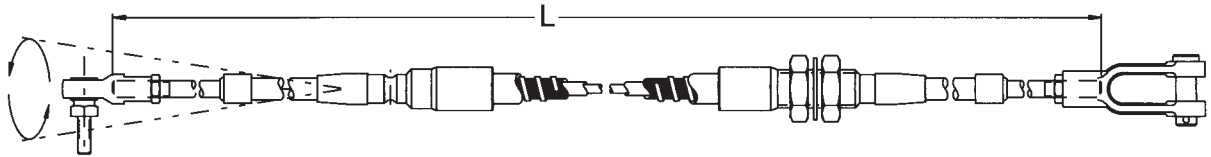

Requires no cab or body design compromise.

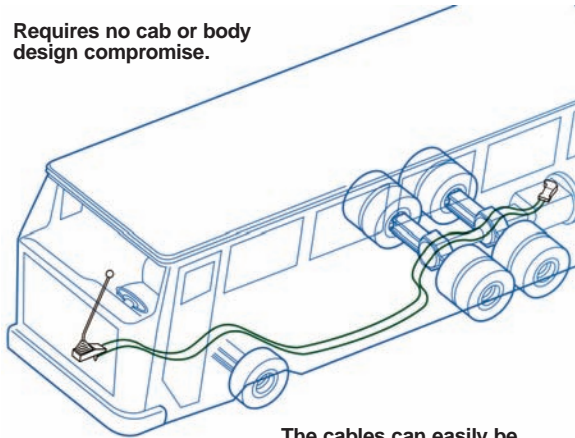

The cables can easily be routed to avoid displacing valuable luggage space.

Tilt cab without disconnecting shift linkage.

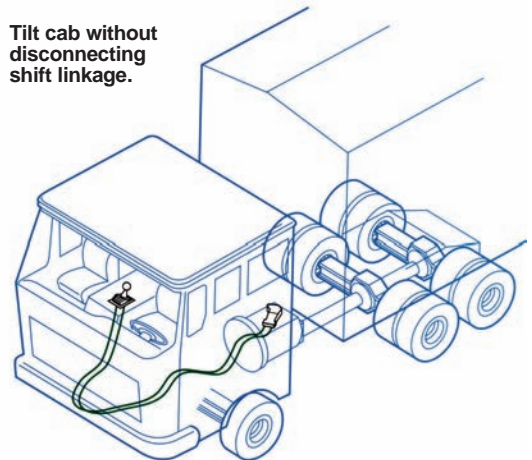

Cab sealed around shift linkage.

- Less Noise
- Cleaner Cab
- Improved Heating and Air Conditioning

No Maintenance Required.

All line art dimensions are represented as follows: in (mm)

VGS Systems

Applications:

- Dash or center console mounted shifter
- Small commercial vehicles
- Servo assisted transmission — bus & coach applications
- Light plant/agricultural vehicles
- Low/medium duty cable applications

Features:

- Easy installation, adjustment free
- Maintenance-free life
- Ends gear jump out
- Clean precise shifts
- No knob-to-cab relative movement in floating cabs
- No action required to tilt cab
- Vibration from drive train is not transmitted
- Reduced cab noise levels
- Low cost
- Installation design to customer requirements
- Flexible capability with different cable end fittings

Material:

- Pressure Die-Cast Aluminum

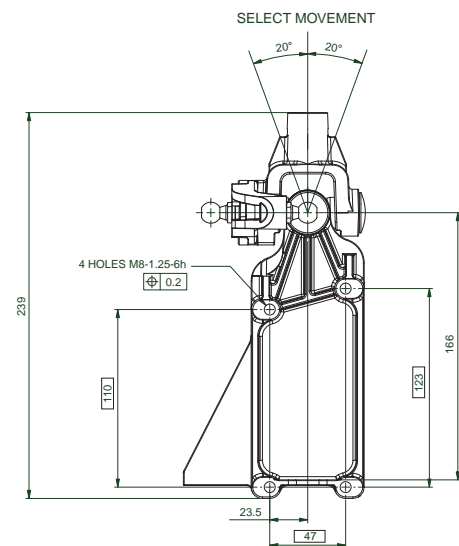
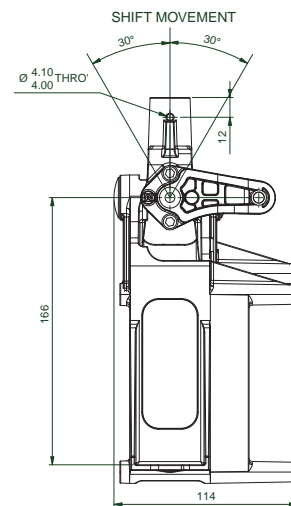
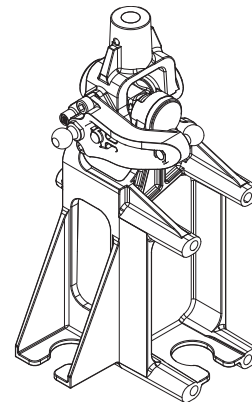
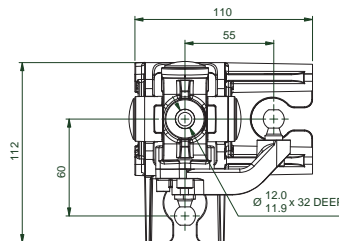
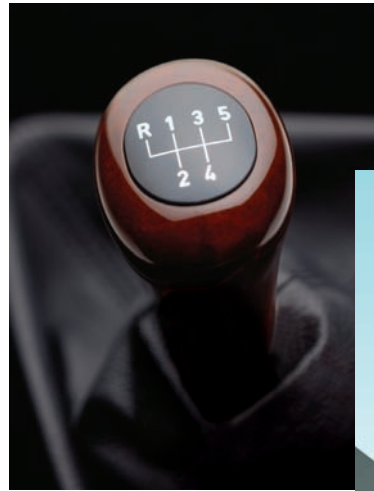

Technical Data

- Recommended handle lengths: 160 mm to 220 mm (6-¼" - 8-¼" approx.)
- Normal working load @ knob = 3kg (6.6 lb.) to 5kg (11 lb.)
- Accidental overload @ knob = 100kg (220 lb.)
- Operating temperatures: -40°C to 120°C (-40°F to 248°F)
- Weight: 1.1 kg (2.4 lb.)

3D CAD Models available upon request.

All line art dimensions are represented as follows: in (mm)

HGS Systems

Applications:

- Floor mounted shifter
- Bus, coach & truck applications
- Servo & non-servo assisted transmissions
- Heavy duty plant/agricultural vehicles
- Heavy/medium duty cable applications

Features:

- Easy installation, adjustment free
- Maintenance-free life
- Ends gear jump out
- Clean precise shifts
- No knob-to-cab relative movement in floating cabs
- No action required to tilt cab
- Vibration from drive train is not transmitted
- Reduced cab noise levels
- Low cost
- Installation design to customer requirements
- Flexible capability with different cable end fittings

Material:

- Pressure Die-Cast Aluminum

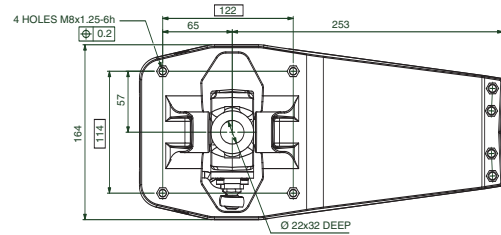
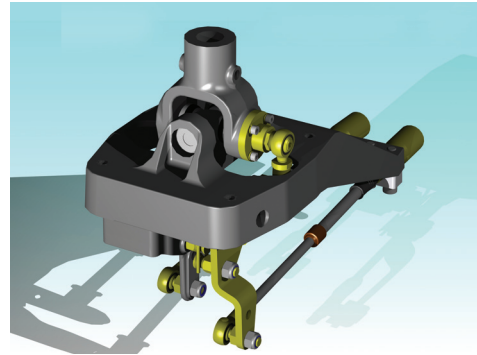
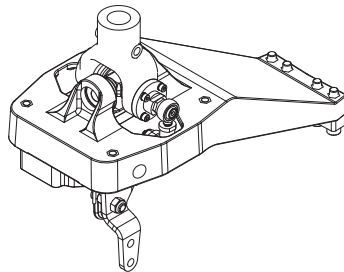

Technical Data

- Recommended handle lengths: 610mm to 760mm (24" - 30" approx.)
- Normal working load @ knob = 3kg (6.6lb.) to 5kg (11lb.)
- Accidental overload @ knob = 100kg (220lb.)
- Operating temperatures: -40°C to 120°C (-40°F to 248°F)
- Weight: 3.2kg (7.0lb.)

3D CAD Models available upon request.

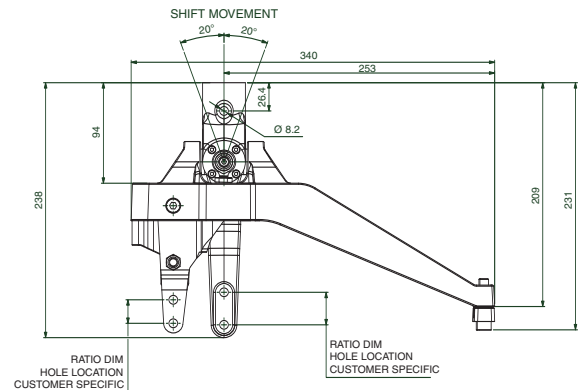
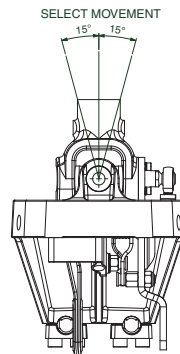

All line art dimensions are represented as follows: in (mm)

HGS Systems

Applications:

- Center console mounted shifter
- Servo & non-servo assisted transmissions
- Bus, coach & truck applications
- Heavy/medium plant/agricultural vehicles
- Heavy/medium duty cable applications

Features:

- Easy installation, adjustment free
- Maintenance-free life
- Ends gear jump out
- Clean precise shifts
- No knob-to-cab relative movement in floating cabs
- No action required to tilt cab
- Vibration from drive train is not transmitted
- Reduced cab noise levels
- Low cost
- Installation design to customer requirements
- Flexible capability with different cable end fittings

Material:

- Pressure Die-Cast Aluminum

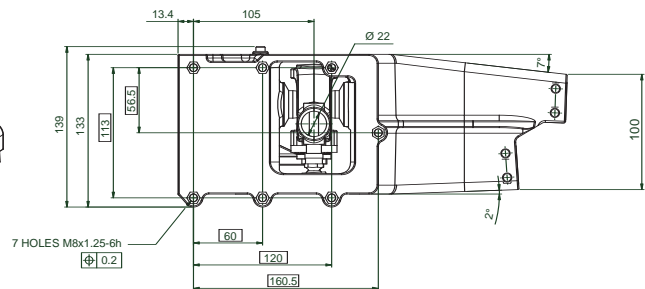
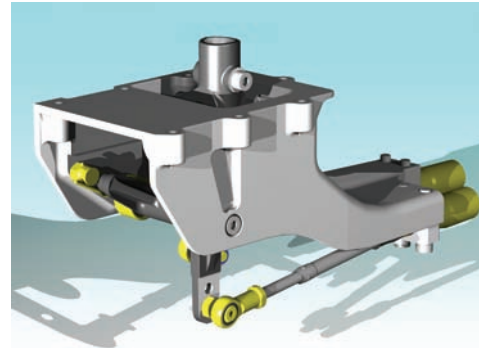
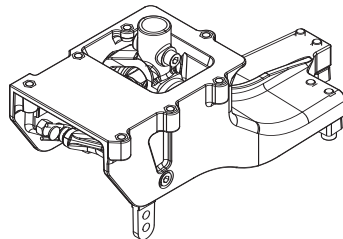

Technical Data

- Recommended handle lengths: 305mm to 380mm (12" - 15" approx.)
- Normal working load @ knob = 3kg (6.6lb.) to 5kg (11lb.)
- Accidental overload @ knob = 100kg (220lb.)
- Operating temperatures: -40°C to 120°C (-40°F to 248°F)
- Weight: 3.0kg (6.6lb.)

3D CAD Models available upon request.

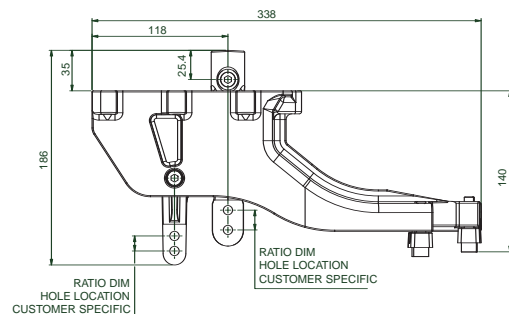
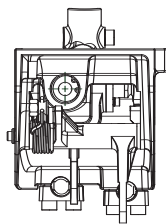

All line art dimensions are represented as follows: in (mm)

Unidrum Lever Control Replacement Cables

| Part No. | Duty | Cap | Travel |
|----------|------|-----|--------|
| A17X-330 | LD | T | 2" |
| A17X-331 | LD | T | 3" |
| A17X-332 | LD | G | 2" |
| A17X-333 | LD | G | 3" |

| Part No. | Duty | Cap | Travel |
|----------|------|-----|--------|
| A17X-530 | VLD | T | 2" |
| A17X-531 | VLD | T | 3" |
| A17X-532 | VLD | G | 2" |
| A17X-533 | VLD | G | 3" |

Part No. A17X-330 Threaded

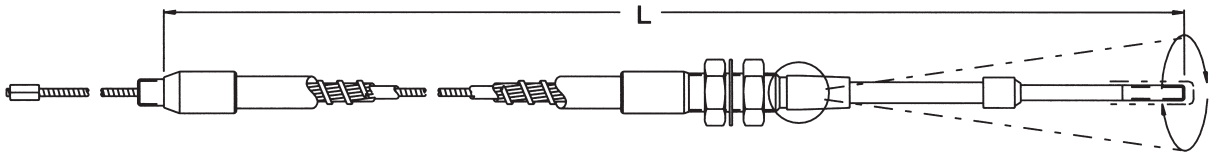

Part No. A17X-332 Grooved

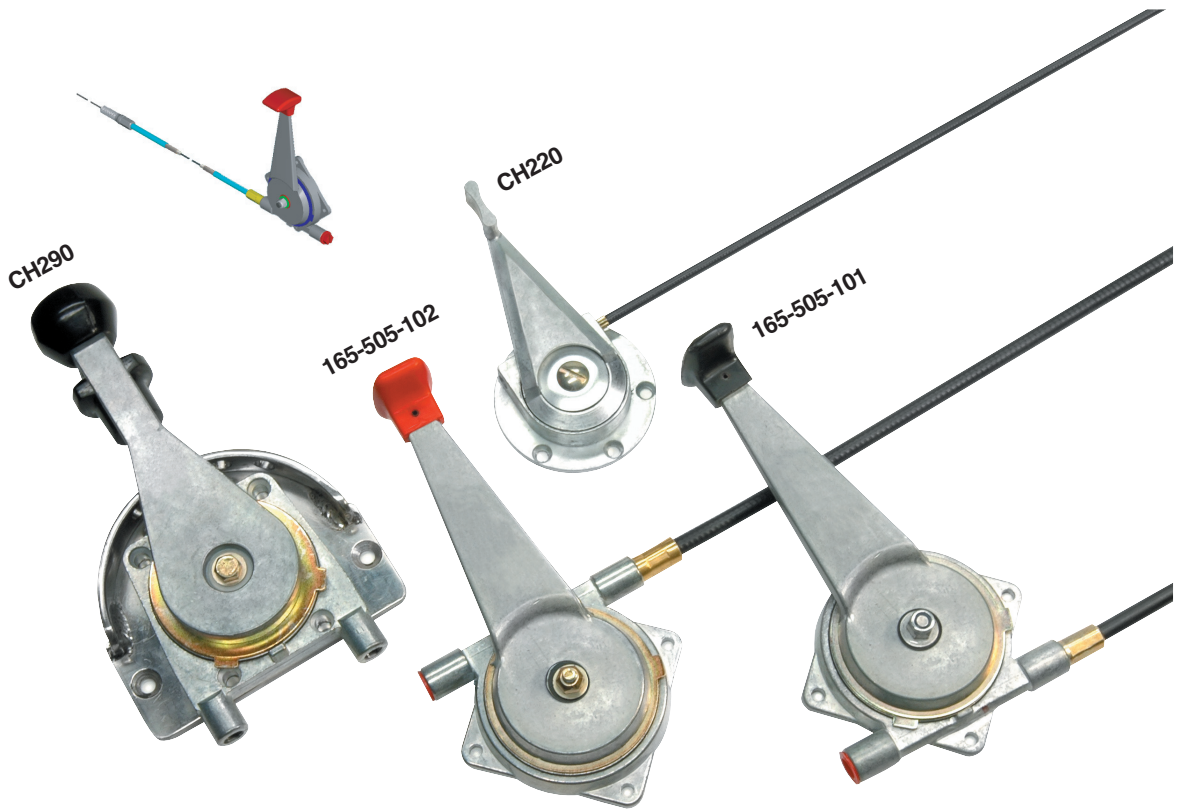
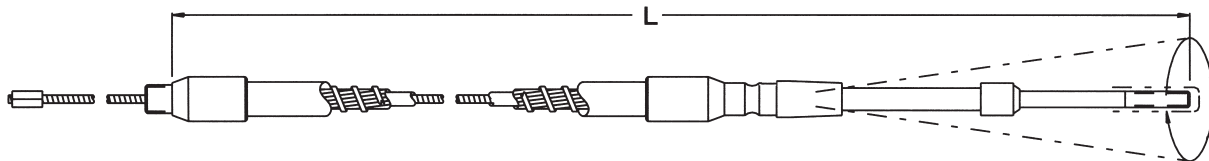

All line art dimensions are represented as follows: in (mm)

Unidrum Lever Control Specialty Cables

Unidrum Lever Control and Cable Combination

Optional lever/cable combinations offer a variety of applications for light lever controls.

Cablecraft® Ordering Codes

Basic Unidrum Lever _____

Knob Color _____

- 1 Black 165-505-101 2 Red 165-505-102

Cable Exit Position (see illustration) _____

- 1 Lower Mount, Left Exit 3 Upper Mount, Left Exit
 2 Lower Mount, Right Exit 4 Upper Mount, Right Exit

Output End Configuration, Cable Size & Type _____

| Style | Size | Type |
|-------------------|------|----------|
| 1 Threaded Swivel | VLD | Utility |
| 2 Grooved Swivel | VLD | Utility |
| 3 Threaded Swivel | LD | Utility |
| 4 Grooved Swivel | LD | Utility |
| 5 Threaded Cap | VLD | Bristow® |
| 6 Grooved Cap | VLD | Bristow® |

Travel (inches) _____

| Cable | Lever |
|-------|--------------|
| 2 2" | approx. 90° |
| 3 3" | approx. 135° |

Overall Length (inches) _____

UDL - 1 - 4 - 4 - 2 - 120

Cable Exit Positions

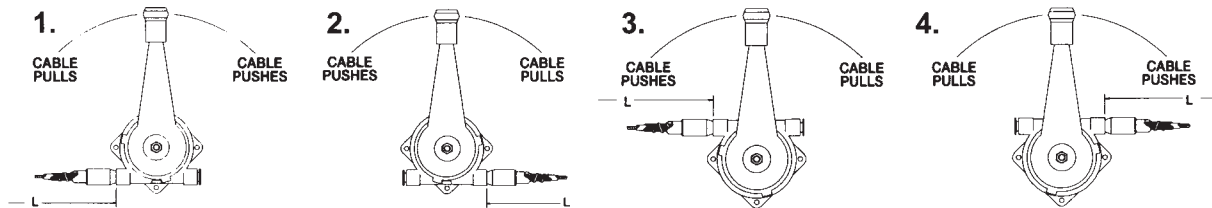

- 1 Threaded Swivel
Dimension A
Per Stroke (extended)
2" 6.94" 3" 8.94"

- 2 Grooved Swivel
Dimension A
Per Stroke (extended)
2" 6.25" 3" 8.25"

- 3 Threaded Swivel
Dimension A
Per Stroke (extended)
2" 7.18" 3" 9.18"

- 4 Grooved Swivel
Dimension A
Per Stroke (extended)
2" 6.56" 3" 8.56"

VLD Utility — Cable Output End Fittings

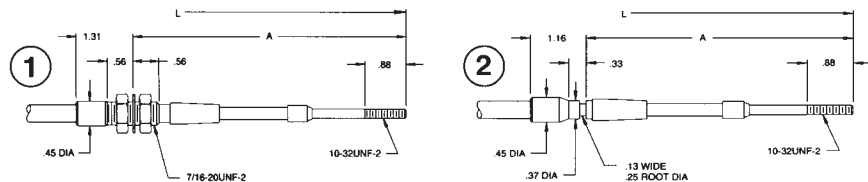

LD Utility — Cable Output End Fittings

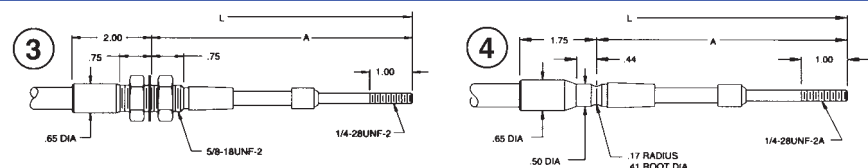

All line art dimensions are represented as follows: in (mm)

Technical/Application Data

Industrial Controls Warnings

The following warnings describe important push-pull cable operation and maintenance information

1. Do not adjust the Cablecraft®/Bristow® control cable with the power on or the engine running. Serious injury or death could result.
2. A gradual or sudden increase in the no-load friction (cable disconnected at both ends) of a Cablecraft®/Bristow® control cable is an indication of a pending or present performance problem. The control cable should be replaced, otherwise serious injury or death may result.
3. A gradual or sudden decrease in the usable stroke, is an indication of a pending or present performance problem. The Cablecraft®/Bristow® control cable should be replaced, otherwise serious injury or death may result.
4. Cablecraft®/Bristow® control cables which have moisture inside of them and/or have frozen should be replaced. Do not apply heat to thaw or dry control cables.
5. Cablecraft®/Bristow® control cables are lubricated for the life of the control cable. Do not remove the seals or lubricate the control cable.
6. Cablecraft®/Bristow® control cables are designed to be non-repairable. Do not attempt to repair this control cable.

WARNING!

Since the manufacturer is unable to determine all applications in which a part may be placed, it is the user's responsibility to determine the suitability of the part for its intended use. This is especially true where safety is a factor. Incorrect application or installation may result in property damage, bodily injury, or death. For application assistance/technical questions, please contact us at the appropriate location listed below or through our website at www.cablecraft.com.

Hardware/End Fittings

Slip Clevis

| Part Number | Thread | Pin Dia. | Length | Inside Opening | Inside Depth |
|-------------|------------|----------|--------|----------------|--------------|
| AC310 | 1/4-28 UNF | 1/4" | 3.25 | .28" | 2.5" |

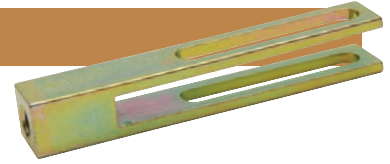

Female Threaded Eye Ends

| Part Number | Internal Threads | Pin Hole | Thickness |
|-------------|------------------|----------|-----------|
| EE9061 | 5/16-24 | 1/4" | .438 |
| EE9069 | 10-32 | 1/4" | .344 |
| EE9151 | 1/4-28 | 1/4" | .344 |
| 185-051-001 | 5/16-24 | 9/32" | .250 |

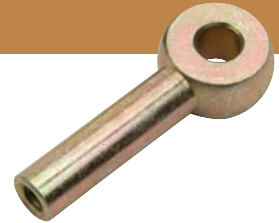

End Rod Thread Adapters

| Part Number | From (Internal) | To (External) |
|-------------|-----------------|---------------|
| 161-009-001 | 1/4-28 | 3/8-28 |
| 161-009-003 | 10-32 | 5/16-24 |
| 161-009-005 | 1/4-28 | 3/8-16 |
| 161-009-006 | 5/16-24 | 3/8-24 |
| 161-009-007 | 10-32 | 1/4-28 |

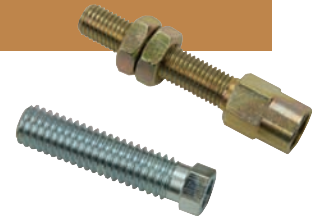

Threaded Pivots

| Part Number | Internal Threads | Pin Dia. | Material Thickness |
|-------------|------------------|----------|--------------------|
| 161-091-000 | 10-32 | 1/4" | 1/4" |
| 161-093-002 | 1/4-28 | 1/4" | 1/4" |
| 161-093-003 | 1/4-28 | 1/4" | 5/16" |



Wire Stop/Pivot

| Part Number | Wire | Pin Dia. | Material Thickness | Set Screw |
|-------------|------|----------|--------------------|-----------|
| 160-450-001 | .075 | 1/4" | 3/16" | 10-32 UNF |
| 160-450-002 | .075 | 1/4" | 5/16" | 10-32 UNF |

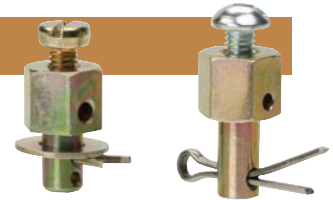

Wire Stop

| Part Number | Hole Size | Set Screw |
|-------------|-----------|---------------------|
| 156-416-002 | .093" | 8-32 UNC Hex Socket |
| 160-429-001 | .138" | 8-32 UNC Slotted |
| 160-429-002 | .093" | 8-32 UNC Slotted |



U-Bolts (furnished with 2 hex nuts)

| Part Number | From (Internal) | To (External) |
|-------------|-----------------|---------------|
| 161-010-001 | 10-32 UNF | VLD |
| 161-010-002 | 1/4-28 | LD |
| 161-010-003 | 5/16-24 | MD |
| 161-010-004 | 3/8-24 | HD |



All line art dimensions are represented in inches

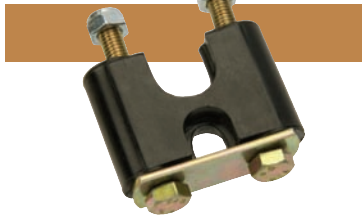

VLD/LD Mounting (fits grooved conduit fitting)

| Part Number |
|-------------|
| ST3652 |



Strap Clamps and Shims

| Use With | Strap | Shim |
|----------|-------------|-------------|
| VLD | 161-011-001 | 175-435-050 |
| LD | 161-011-002 | 175-435-051 |

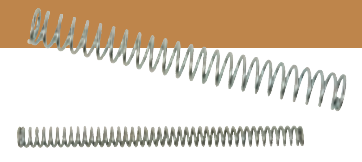

Compression Springs (for brake cables)

| Part Number | Inside Dia. | Outside Dia. | Length | Solid Height | Spring Rate |
|-------------|-------------|--------------|--------|--------------|---------------|
| 175-923-001 | .30 | .437 | 12.0 | 4.60 | 3.93 lb/inch |
| 175-923-002 | .30 | .437 | 6.4 | 3.20 | 5.75 lb/inch |
| 175-923-006 | .30 | .437 | 5.7 | 2.87 | 6.23 lb/inch |
| 175-924-001 | .26 | .437 | 10.0 | 6.62 | 15.97 lb/inch |
| 175-925-003 | .40 | .500 | 4.3 | 1.00 | 4.47 lb/inch |



Bellows (trim to length)

| Part Number | For Use With Cable Size |
|-------------|-------------------------|
| 175-435-072 | VLD |
| 175-435-081 | LD |
| 175-435-082 | MD |

| Part Number | For Use With Cable Size | Compressed Length | Extended Length | Max Travel |
|-------------|-------------------------|-------------------|-----------------|------------|
| 175-522-001 | VLD | 3.0" | 8.0 | 6.0" |
| 175-524-002 | LD | 3.4" | 9.7 | 6.0" |
| 175-525-001 | MD | 4.5" | 11.3 | 6.0" |

Maximum recommended is shown.
 Must be trimmed shorter for use on shorter travel cables.
 See cutting matrix #CC-111. Adapter rings to mount bellows to conduit fittings.

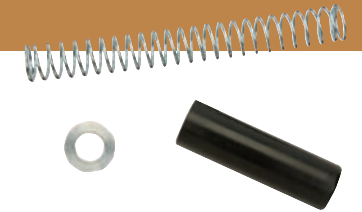

Spring Return Kit

Convert any LD size, 2" travel threaded swivel end to spring loaded to extended position.
 Force with end rod extended - 4.6 lb
 Force with end rod retracted - 15.2 lb

| Part Numbers | |
|--------------|-------------|
| Spring | 175-930-001 |
| Collar | 175-435-118 |
| Outer Guide | 160-071-025 |



Umbrella Seal

| Part Number | For Use With Cable Size |
|-------------|-------------------------|
| 160-071-005 | VLD, 2" |
| 160-071-006 | VLD, 3" |
| 160-071-007 | VLD, 4" |
| 160-071-008 | LD, 2" |
| 160-071-009 | LD, 3" |
| 160-071-010 | LD, 4" |
| 160-071-011 | MD, 2" |
| 160-071-012 | MD, 3" |
| 160-071-013 | MD, 4" |

All line art dimensions are represented in inches

Knobs/Handles

| Part Number | Type | Thread Size |
|-------------|---------------------------|-------------|
| 165-183-001 | PTO | 1/4-28 |
| 165-183-002 | PTO | 1/4-20 |
| 165-183-003 | PTO | 5/16-18 |
| 165-183-004 | PTO | 5/16-24 |
| 165-103-001 | 2" Mushroom | 1/4-28 |
| 165-103-002 | 2" Mushroom | 1/4-20 |
| 165-103-004 | 2" Mushroom | 3/8-24 |
| 165-103-006 | 2" Mushroom | 5/16-18 |
| 165-038-124 | 2" Mushroom | 1/2-13 |
| 165-038-106 | 1-3/8" dia. x 4-3/8" tall | 1/2-13 |
| 165-172-201 | 3-1/2" Aluminum T | 1/4-20 |
| 165-172-202 | 3-1/2" Aluminum T | 1/4-28 |
| 165-172-203 | 3-1/2" Aluminum T | 5/16-28 |
| 165-172-206 | 3-1/2" Alum./Black T | 1/4-20 |
| 300-057-008 | 3-1/2" Alum. Twist Lock T | N/A |



Hydroback

| Part Number | Travel | Spring Force at Center | For Use With Cable Size |
|-------------|--------|------------------------|-------------------------|
| 165-073-210 | 2" | 10 lb | LD |
| 165-073-220 | 2" | 20 lb | LD |
| 165-073-310 | 3" | 10 lb | LD |
| 165-073-320 | 3" | 20 lb | LD |
| 165-072-210 | 2" | 10 lb | MD |
| 165-072-220 | 2" | 20 lb | MD |
| 165-072-310 | 3" | 10 lb | MD |
| 165-072-320 | 3" | 20 lb | MD |



Spool Valve Adapters - Open Style Mount

| Part Number | For Use On |
|-------------|---|
| 185-101-001 | Comm. Shearing 505 |
| 185-101-002 | Comm. Shearing D50 |
| 185-101-003 | Comm. Shearing A35 |
| 185-101-004 | Comm. Shearing A20 |
| 185-101-005 | Comm. Shearing VA20 |
| 185-101-006 | Husco 6000 |
| 185-101-007 | Husco 7120 |
| 185-101-008 | Gresen V20, V31P, V42, CP, CT, CPT, CS, 25P, 25PK |



Modulator Assemblies and Replacement Cables

| Cable Output End | MODULATOR UNIT WITH CABLE | | Cable Only |
|-------------------|---------------------------|-----------------|------------|
| | Pull To Operate | Push To Operate | |
| A. Grooved Mount | | | |
| 173 Utility | CA 343-3-001-L | CA 343-3-002-L | CA 343-3-L |
| 174 Utility | CA 343-4-001-L | CA 343-4-002-L | CA 343-4-L |
| B. Threaded Mount | | | |
| 173 Utility | CA 341-3-001-L | CA 341-3-002-L | CA 341-3-L |
| 174 Utility | CA 341-4-001-L | CA 341-4-002-L | CA 341-4-L |



REPLACEMENT CABLES ONLY FOR OTHER USA MANUFACTURED MODULATORS

| Cable Output End | 173 Utility | 174 Utility |
|------------------|-------------|-------------|
| Grooved Mount | CA 213 G-L | CA 214 G-L |
| Threaded Mount | CA 213 T-L | CA 214 T-L |



All line art dimensions are represented in inches

Cablecraft Motion Controls Industrial Linkages

Cablecraft Motion Controls is the leading designer and manufacturer of motion transfer components and a long time leader in rod ends, ball joints and custom linkages. Suitable for many mechanical motion transfer applications, our rod ends can be used in a wide range of operating temperatures. Studded and right or left-handed thread versions are available. Grease fittings are optional on some sizes.

Our ball joints are also suitable for applications in a wide temperature range. Metal to metal, integral ball joints, plastic ball joints or quick disconnect solutions are available.

Cablecraft Motion Controls also provides complete motion transfer assemblies or sub-assemblies to fit your application requirements. Standard products and custom-engineered solutions. Cablecraft Motion Controls rod ends and ball joints are found in the following applications & markets:

- Tie Rods
- Drag Links
- Steering Controls
- Operator Controls
- Printing & Labeling Equipment
- Hydraulic/Pneumatic Cylinder Ends
- Food Processing
- Door Mechanisms
- Conveying Equipment

Remember to have this information ready whenever possible:

- Diameter (thread size) of the product?
- Race construction: 2-piece, molded nylon, bronze?
- Body & ball material: Low carbon or stainless steel?
- Male or female threads, right hand or left hand?
- Plain or with an optional stud?

It helps to have this additional information:

- What is the application?
- Load info: actual working load?
- Conditions/environment: Dirt, heat, cold, moisture, etc?
- If available, part number?
- Usage quantity?

Technical/Application Data

Cablecraft Motion Controls' engineering staff possesses the expertise to provide advice and guidelines regarding nearly all motion transmission applications.

There are several factors pertaining to engineering application, including correct installation, that should be taken into consideration to insure optimum performance of your chosen linkage components.

- 1.** When mounting ball studs, the hex mounting portion should be properly tightened and flat against its mating surface. Adequate countersinks, counterbores or washers may be necessary to provide a tight, flush joint. Installation torque values for tightening must be within the capacity of the linkage component or breakage may occur from over-tightening. Consult our engineering staff or refer to an appropriate engineering standard for mounting nut torque values associated with each grade of threaded fastener. Looseness in the threaded joint or mounting surface may cause abnormal wear and early failure of the linkage component.
- 2.** When mounting rod ends, care should be used in tightening a fastener against the ball to prevent distortion. The same torque requirements that apply to threaded fasteners also apply to securing the rod end spherical ball. The plated ball may become chipped or distorted by excessive clamping pressure, resulting in increased torque, wear, and premature failure of the rod end.
- 3.** In applications involving vibration where loosening of the linkage components may occur, self-locking nuts or lockwashers should be used to secure the components and prevent loosening. Looseness in the threaded joint or mounting surface may cause abnormal wear and early failure of the linkage component.
- 4.** Ball joints and rod end bearings should be mounted in such a way as to best utilize the design of the joint with respect to gravitational force. For example, a ball joint should be mounted with the housing member on top of the ball stud. Mounting the housing component with its weight and linkage hanging from the ball or ball stud could accelerate wear and lead to detachment of linkage components and sudden loss of control.
- 5.** It is recommended that a separate stop be incorporated in the linkage system to eliminate the possibility of exceeding the misalignment capability of the ball joint or rod end bearing. An overtravel condition of this type may result in breakage and detachment of the ball joint or rod end components and sudden loss of control.
- 6.** Our ball joints and rod end bearings are manufactured to commercial standards. If you have questions concerning a particular product for your application, Cablecraft Motion Controls can offer assistance; however, it is the end user's responsibility to determine if the chosen part is suitable for a specific application (especially true where safety is a factor).
- 7.** To determine a part's useful life for a particular application, you should test sample parts under actual operating conditions.

Load Definitions

Ultimate Radial Static Load Capacity

These loads are the maximum amount of force the part can sustain before complete failure. All loads listed in the catalog are based on rod ends without grease fittings. Due to the removal of material for the fitting, the load rating for such a part is substantially lower. Consult our engineering department for assistance on these parts.

Radial Static Load Capacity

These loads are the maximum amount of force the part can sustain before a 2% permanent set occurs in the part. Consult our engineering department if these numbers don't fit your application.

Static Limit Load

Static limit load is the allowable load that can be applied to a bearing without adversely affecting its performance capabilities.

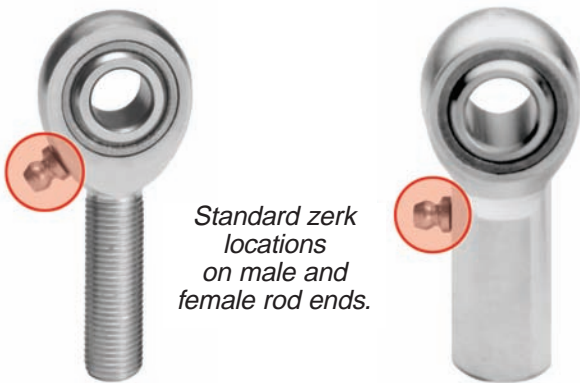

Standard zerk locations on male and female rod ends.

Rod End Keyway (Ref NAS 559)

| Dimensions in Inches | | | | |
|----------------------|--------|--------|--------|--------|
| THREAD OD REF | N MAX. | P MIN. | N MAX. | P MIN. |
| .2500 | .056 | .062 | .201 | .255 |
| .3125 | .056 | .062 | .260 | .255 |
| .3750 | .056 | .093 | .311 | .255 |
| .4375 | .069 | .093 | .370 | .255 |
| .5000 | .069 | .093 | .436 | .255 |
| .5620 | .077 | .125 | .478 | .255 |
| .6250 | .077 | .125 | .541 | .255 |
| .7500 | .077 | .125 | .663 | .255 |
| .8750 | .086 | .156 | .777 | .318 |
| 1.0000 | .094 | .156 | .900 | .318 |
| 1.1250 | .094 | .094 | 1.010 | .382 |
| 1.2500 | .116 | .187 | 1.136 | .382 |
| 1.3750 | .116 | .187 | 1.236 | .445 |
| 1.5000 | .116 | .250 | 1.361 | .445 |
| 1.6250 | .129 | .250 | 1.477 | .445 |
| 1.7500 | .129 | .250 | 1.589 | .508 |
| 1.8750 | .129 | .312 | 1.714 | .508 |
| 2.0000 | .129 | .312 | 1.839 | .508 |
| 2.1250 | .129 | .312 | 1.955 | .508 |
| 2.2500 | .129 | .312 | 2.080 | .508 |

Standard Drive Fit Zerk

Specify by adding suffix "Z" to part number.

Example: MSF8Z

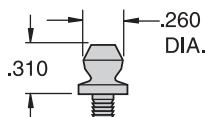

Standard Threaded Zerk

Specify by adding suffix "-28" to part number.

Example: MSF8Z-28

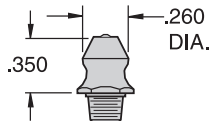

Metric Zerk

Specify by adding suffix "ZM" to part number.

Example: MSF8ZM

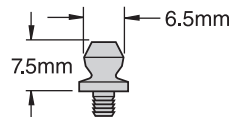

Note: Zerks not available on 3/8" or 10mm and smaller rod ends.

Rod Ends/Ball Joints: Specifying Tips

Each of our products is specifically designed to perform in even the most extreme conditions. Through this technical guide and the advice of our sales and engineering staff, our goal is to help you identify the most appropriate Cablecraft product suited to your application. First, a few key considerations...

While the applications are almost limitless, the conditions that the different linkages witness are often very similar. **When designing a linkage solution, keep in mind everything from environmental conditions (humidity, dust & temperature) to the range of motion required.**

- For example: Rod ends and ball joints are not designed for high rate rotational applications such as holding rotating shafts. However, when repetitive motion is present, one of our many **self-lubricated bearings (such as nylon, bronze or PTFE lined race bearings)** should be considered. Our comprehensive catalog provides individual product pages that identify key features such as temperature restraints and descriptions of strength for each product.
- **When environmental conditions involving excessive dirt exist, our nylon race bearings** help keep the cavity free of excessive dirt build-up (a great alternative to the “tough to reach linkage and often-neglected grease fitting” applications).
- Additionally Cablecraft Motion Controls provides many **specialty alloy designs** to prevent corrosion and increase strengths.

Why choose a ball joint instead of a rod end? While ball joints are often considered the more economical solution, there are also many cases in which a ball joint is better suited for performance and geometry-based applications. Our ball joints come in many forms aside from designs in the catalog. A popular and flexible design option includes our 1-piece solid and bent linkages (as seen on many draglinks and tie rods in the lawn and garden industry). The integral ball joint placed directly in the connecting rod creates a low profile linkage that is optimal for minimal clearance applications such as steering and other internal machine controls.

What sets us apart from other rod end and ball joint manufacturers? Cablecraft Motion Controls not only designs all of our rod ends, ball joints and sphericals, but also manufactures them in the USA. Since 1920, we have been creating and developing many of the critical and revolutionary methods to manufacture linkages. This has put us in the forefront of product offerings, and to this day we continue to strive to offer the best product, the best delivery and the best value to our customers. Call 260-749-5105 when you need product/technical engineering support.

WARNING!

Since the manufacturer is unable to determine all applications in which a part may be placed, it is the user's responsibility to determine the suitability of the part for its intended use. This is especially true where safety is a factor. Incorrect application or installation may result in property damage, bodily injury, or death. For technical assistance, call 260-749-5105.

SPM/SPF Rod Ends

Molded Race, Self-Lubricating

Applications:

Numerous mechanical motion transfer devices/applications, including:

- Construction equipment
- Recreational vehicles (ATV's, golf carts, etc.)
- Truck/off highway

Features:

- Nylon molded raceway delivers self-lubricating low friction and moisture-resistant performance
- Good wear resistance
- Design allows for control of breakaway torque, adding to its application versatility
- Can be used in a wide range of temperatures: -30°F — 220°F (-34°C — 104°C)
- Offered in studded and right or left-handed versions
- Custom assemblies can be built to your specifications
- Meets SAE spec J1120

Material:

- **Ball** - Low Carbon Steel, Case Hardened Zinc Plated, Yellow Dichromate Treated
- **Body** - Low Carbon Steel Zinc Plated, Yellow Dichromate Treated
- **Race** - Molded Self-Lubricating Reinforced Nylon

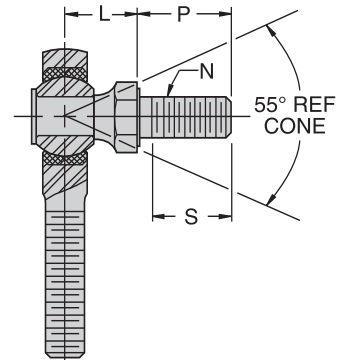

| Studded Dimensions | | | | |
|--------------------|-------|----------|----------------------|----------------------|
| Rod End Bore Size | L REF | P ± .030 | S Min. Thread Length | N Thread Size UNF-2A |
| 3/16" | .437 | .438 | .375 | 10-32 |
| 1/4" | .469 | .563 | .500 | 1/4-28 |
| 5/16" | .531 | .688 | .594 | 5/16-24 |
| 3/8" | .625 | .875 | .781 | 3/8-24 |
| 7/16" | .844 | 1.062 | .937 | 7/16-20 |
| 1/2" | .875 | 1.125 | 1.000 | 1/2-20 |
| 5/8" | 1.000 | 1.125 | 1.000 | 5/8-18 |
| 3/4" | 1.187 | 1.812 | 1.625 | 3/4-16 |

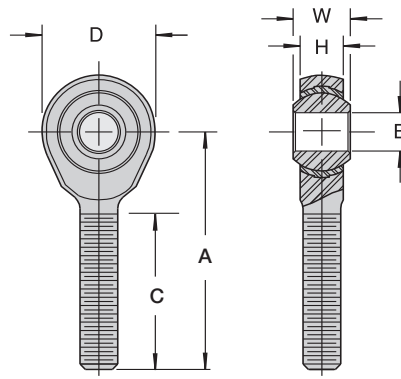

SPM Male Chart

| Part Number | | B +.0020 -.0000 | W ±.005 | H REF | A ±.015 | D ±.015 | REF | C ±.060 | UNF-2A | Ultimate Radial Static Load Capacity (Pounds) | Weight (Pounds) |
|-------------|-----------|-----------------------|------------|---------------|-------------------|---------------|---------------|---------------|-------------|---|-----------------|
| Right Hand | Left Hand | Ball Bore | Ball Width | Housing Width | Centerline Length | Head Diameter | Ball Diameter | Thread Length | Thread Size | | |
| SPM3 | SPML3 | .1900 | .312 | .250 | 1.250 | .625 | .438 | .750 | 10-32 | 1,210 | .023 |
| SPM4 | SPML4 | .2500 | .375 | .281 | 1.562 | .750 | .516 | 1.000 | 1/4-28 | 2,470 | .040 |
| SPM5 | SPML5 | .3125 | .437 | .344 | 1.875 | .875 | .625 | 1.250 | 5/16-24 | 2,740 | .071 |
| SPM6 | SPML6 | .3750 | .500 | .406 | 1.937 | 1.000 | .719 | 1.250 | 3/8-24 | 4,210 | .107 |
| SPM7 | SPML7 | .4375 | .562 | .437 | 2.125 | 1.125 | .812 | 1.312 | 7/16-20 | 5,350 | .148 |
| SPM8 | SPML8 | .5000 | .625 | .500 | 2.437 | 1.312 | .938 | 1.500 | 1/2-20 | 6,430 | .232 |
| SPM10 | SPML10 | .6250 | .750 | .562 | 2.625 | 1.500 | 1.125 | 1.625 | 5/8-18 | 8,300 | .364 |
| SPM12 | SPML12 | .7500 | .875 | .687 | 2.875 | 1.750 | 1.312 | 1.750 | 3/4-16 | 10,900 | .568 |

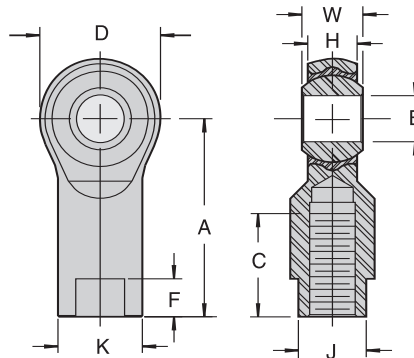

SPF Female Chart

| Part Number | | B +.0020 -.0000 | W ±.005 | H REF | A ±.015 | D ±.015 | K ±.015 | J ±.015 | F ±.030 | REF | C ±.060 | UNF-2B | Ultimate Radial Static Load Capacity (Pounds) | Weight (Pounds) |
|-------------|-----------|-----------------------|------------|---------------|-------------------|---------------|----------------|-------------------|--------------------|---------------|---------------|-------------|---|-----------------|
| Right Hand | Left Hand | Ball Bore | Ball Width | Housing Width | Centerline Length | Head Diameter | Shank Diameter | Wrench Flat Width | Wrench Flat Length | Ball Diameter | Thread Length | Thread Size | | |
| SPF3 | SPFL3 | .1900 | .312 | .250 | 1.062 | .625 | .406 | .312 | .406 | .438 | .562 | 10-32 | 1,210 | .036 |
| SPF4 | SPFL4 | .2500 | .375 | .281 | 1.312 | .750 | .469 | .375 | .281 | .516 | .750 | 1/4-28 | 2,470 | .059 |
| SPF5 | SPFL5 | .3125 | .437 | .344 | 1.375 | .875 | .500 | .437 | .281 | .625 | .750 | 5/16-24 | 2,740 | .077 |
| SPF6 | SPFL6 | .3750 | .500 | .406 | 1.625 | 1.000 | .687 | .562 | .312 | .719 | .937 | 3/8-24 | 4,100 | .146 |
| SPF7 | SPFL7 | .4375 | .562 | .437 | 1.812 | 1.125 | .750 | .625 | .625 | .812 | 1.031 | 7/16-20 | 5,350 | .192 |
| SPF8 | SPFL8 | .5000 | .625 | .500 | 2.125 | 1.312 | .875 | .750 | .375 | .938 | 1.187 | 1/2-20 | 6,430 | .313 |
| SPF10 | SPFL10 | .6250 | .750 | .562 | 2.500 | 1.500 | 1.000 | .875 | .500 | 1.125 | 1.500 | 5/8-18 | 8,300 | .464 |
| SPF12 | SPFL12 | .7500 | .875 | .687 | 2.875 | 1.750 | 1.125 | 1.000 | 1.000 | 1.312 | 1.562 | 3/4-16 | 10,900 | .672 |

Chart Notes: This series is also available in a studded configuration. Specify by adding "S" to suffix. Example: SPF8S

SSPM/SSPF Rod Ends

Stainless Steel, Molded Race, Self-Lubricating

Applications:

Numerous mechanical motion transfer devices/applications, including:

- Marine
- Construction equipment
- Recreational vehicles (ATV's, golf carts, etc.)
- Truck/off highway

Features:

- Stainless steel construction for extra corrosion protection
- Nylon molded race delivers self-lubricating low friction and moisture-resistant performance
- Good wear resistance
- Design allows for control of breakaway torque, adding to its application versatility
- Can be used in a wide range of temperatures: -30°F — 220°F (-34°C — 104°C)
- Offered in studded and right or left-handed versions
- Custom assemblies can be built to your specifications
- Meets SAE spec J1120

Material:

- **Ball** - Stainless Steel
- **Body** - Stainless Steel
- **Race** - Molded Self-Lubricating Reinforced Nylon
- **Stud (optional)** - Stainless Steel

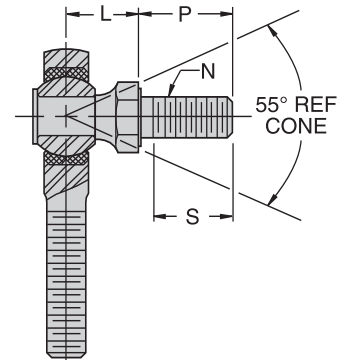

| Studded Dimensions | | | | |
|--------------------|-------|----------|----------------------|----------------------|
| Rod End Bore Size | L REF | P ± .030 | S Min. Thread Length | N Thread Size UNF-2A |
| 3/16" | .437 | .438 | .375 | 10-32 |
| 1/4" | .469 | .563 | .500 | 1/4-28 |
| 5/16" | .531 | .688 | .594 | 5/16-24 |
| 3/8" | .625 | .875 | .781 | 3/8-24 |
| 7/16" | .844 | 1.062 | .937 | 7/16-20 |
| 1/2" | .875 | 1.125 | 1.000 | 1/2-20 |
| 5/8" | 1.000 | 1.125 | 1.000 | 5/8-18 |
| 3/4" | 1.187 | 1.812 | 1.625 | 3/4-16 |

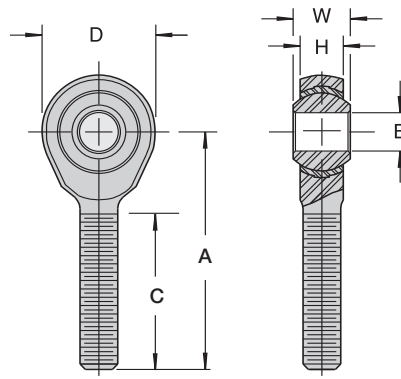

SSPM Male Chart

| Part Number | | B +.0020 -.0000 | W ±.005 | H REF | A ±.015 | D ±.015 | REF | C ±.060 | UNF-2A | Ultimate Radial Static Load Capacity (Pounds) | Weight (Pounds) |
|-------------|-----------|-----------------------|------------|---------------|-------------------|---------------|---------------|---------------|-------------|---|-----------------|
| Right Hand | Left Hand | Ball Bore | Ball Width | Housing Width | Centerline Length | Head Diameter | Ball Diameter | Thread Length | Thread Size | | |
| SSPM3 | SSPML3 | .1900 | .312 | .250 | 1.250 | .625 | .438 | .750 | 10-32 | 1,210 | .023 |
| SSPM4 | SSPML4 | .2500 | .375 | .281 | 1.562 | .750 | .516 | 1.000 | 1/4-28 | 2,470 | .040 |
| SSPM5 | SSPML5 | .3125 | .437 | .344 | 1.875 | .875 | .625 | 1.250 | 5/16-24 | 2,740 | .071 |
| SSPM6 | SSPML6 | .3750 | .500 | .406 | 1.937 | 1.000 | .719 | 1.250 | 3/8-24 | 4,210 | .107 |
| SSPM7 | SSPML7 | .4375 | .562 | .437 | 2.125 | 1.125 | .812 | 1.312 | 7/16-20 | 5,350 | .148 |
| SSPM8 | SSPML8 | .5000 | .625 | .500 | 2.437 | 1.312 | .938 | 1.500 | 1/2-20 | 6,430 | .232 |
| SSPM10 | SSPML10 | .6250 | .750 | .562 | 2.625 | 1.500 | 1.125 | 1.625 | 5/8-18 | 8,300 | .364 |
| SSPM12 | SSPML12 | .7500 | .875 | .687 | 2.875 | 1.750 | 1.312 | 1.750 | 3/4-16 | 10,900 | .568 |

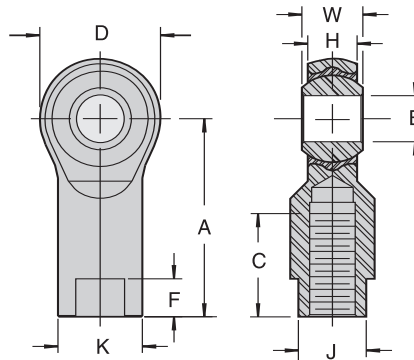

SSPF Female Chart

| Part Number | | B +.0020 -.0000 | W ±.005 | H REF | A ±.015 | D ±.015 | K ±.015 | J ±.015 | F ±.030 | REF | C ±.060 | UNF-2B | Ultimate Radial Static Load Capacity (Pounds) | Weight (Pounds) |
|-------------|-----------|-----------------------|------------|---------------|-------------------|---------------|----------------|-------------------|--------------------|---------------|---------------|-------------|---|-----------------|
| Right Hand | Left Hand | Ball Bore | Ball Width | Housing Width | Centerline Length | Head Diameter | Shank Diameter | Wrench Flat Width | Wrench Flat Length | Ball Diameter | Thread Length | Thread Size | | |
| SSPF3 | SSPFL3 | .1900 | .312 | .250 | 1.062 | .625 | .406 | .312 | .406 | .438 | .562 | 10-32 | 1,210 | .036 |
| SSPF4 | SSPFL4 | .2500 | .375 | .281 | 1.312 | .750 | .469 | .375 | .281 | .516 | .750 | 1/4-28 | 2,470 | .059 |
| SSPF5 | SSPFL5 | .3125 | .437 | .344 | 1.375 | .875 | .500 | .437 | .281 | .625 | .750 | 5/16-24 | 2,740 | .077 |
| SSPF6 | SSPFL6 | .3750 | .500 | .406 | 1.625 | 1.000 | .687 | .562 | .312 | .719 | .937 | 3/8-24 | 4,100 | .146 |
| SSPF7 | SSPFL7 | .4375 | .562 | .437 | 1.812 | 1.125 | .750 | .625 | .625 | .812 | 1.031 | 7/16-20 | 5,350 | .192 |
| SSPF8 | SSPFL8 | .5000 | .625 | .500 | 2.125 | 1.312 | .875 | .750 | .375 | .938 | 1.187 | 1/2-20 | 6,430 | .313 |
| SSPF10 | SSPFL10 | .6250 | .750 | .562 | 2.500 | 1.500 | 1.000 | .875 | .500 | 1.125 | 1.500 | 5/8-18 | 8,300 | .464 |
| SSPF12 | SSPFL12 | .7500 | .875 | .687 | 2.875 | 1.750 | 1.125 | 1.000 | 1.000 | 1.312 | 1.562 | 3/4-16 | 10,900 | .672 |

Chart Notes: This series is also available in a studded configuration. Specify by adding "S" to suffix. Example: SSPF8S

EM/EF Rod Ends

Commercial, 2-Piece,
Metal to Metal

Applications:

Numerous mechanical motion transfer devices/applications, including:

- Construction equipment
- Lawn and garden
- Truck/bus

Features:

- 2-piece metal to metal design offers our most economical option
- Suited for higher axial load where side loading strength is critical
- Can be used in a wide range of temperatures: -65°F — 250°F (-54°C — 121°C)
- Offered in studed and right or left-handed versions
- Custom assemblies can be built to your specifications
- Meets SAE spec J1120

Material:

- **Ball** - Low Carbon Steel, Case Hardened
Zinc Plated, Yellow Dichromate Treated
- **Body** - Low Carbon Steel
Zinc Plated, Yellow Dichromate Treated

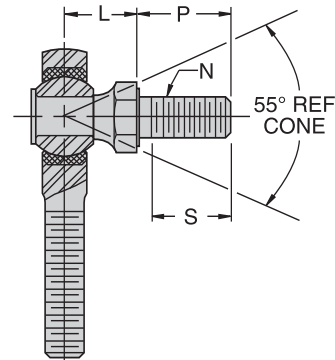

| Studded Dimensions | | | | |
|--------------------|-------|----------|----------------------|----------------------|
| Rod End Bore Size | L REF | P ± .030 | S Min. Thread Length | N Thread Size UNF-2A |
| 1/4" | .469 | .563 | .500 | 1/4-28 |
| 5/16" | .531 | .688 | .594 | 5/16-24 |
| 3/8" | .625 | .875 | .781 | 3/8-24 |
| 1/2" | .875 | 1.125 | 1.000 | 1/2-20 |
| 5/8" | 1.000 | 1.125 | 1.000 | 5/8-18 |

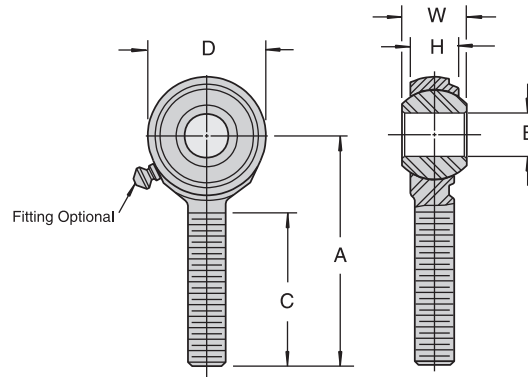

EM Chart

| Part Number | | B +.0020 -.0000 | W ±.005 | H REF | A ±.015 | D ±.015 | REF | C ±.060 | UNF-2A | Ultimate Radial Static Load Capacity (Pounds) | Weight (Pounds) |
|-------------|-----------|-----------------------|------------|---------------|-------------------|---------------|---------------|---------------|-------------|---|-----------------|
| Right Hand | Left Hand | Ball Bore | Ball Width | Housing Width | Centerline Length | Head Diameter | Ball Diameter | Thread Length | Thread Size | | |
| EM4 | EML4 | .2500 | .375 | .281 | 1.562 | .750 | .516 | 1.000 | 1/4-28 | 2,510 | .043 |
| EM5 | EML5 | .3125 | .437 | .344 | 1.875 | .875 | .625 | 1.250 | 5/16-24 | 3,430 | .073 |
| EM6 | EML6 | .3750 | .500 | .406 | 1.937 | 1.000 | .719 | 1.250 | 3/8-24 | 5,520 | .110 |
| EM8 | EML8 | .5000 | .625 | .500 | 2.437 | 1.312 | .938 | 1.500 | 1/2-20 | 8,690 | .240 |
| EM10 | EML10 | .6250 | .750 | .562 | 2.625 | 1.500 | 1.125 | 1.625 | 5/8-18 | 10,300 | .368 |

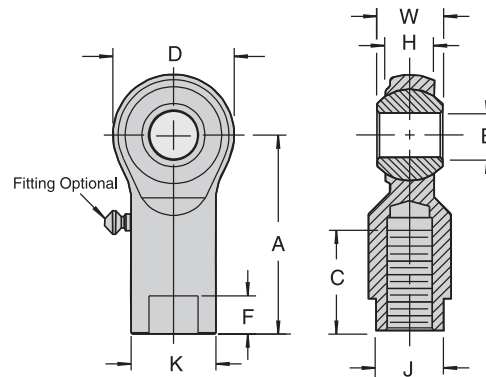

EF Chart

| Part Number | | B +.0020 -.0000 | W ±.005 | H REF | A ±.015 | D ±.015 | K ±.015 | J ±.015 | F ±.030 | REF | C ±.060 | UNF-2B | Ultimate Radial Static Load Capacity (Pounds) | Weight (Pounds) |
|-------------|-----------|-----------------------|------------|---------------|-------------------|---------------|----------------|-------------------|--------------------|---------------|---------------|-------------|---|-----------------|
| Right Hand | Left Hand | Ball Bore | Ball Width | Housing Width | Centerline Length | Head Diameter | Shank Diameter | Wrench Flat Width | Wrench Flat Length | Ball Diameter | Thread Length | Thread Size | | |
| EF4 | EFL4 | .2500 | .375 | .281 | 1.312 | .750 | .469 | .375 | .250 | .516 | .687 | 1/4-28 | 3,470 | .062 |
| EF5 | EFL5 | .3125 | .437 | .344 | 1.375 | .875 | .500 | .437 | .281 | .625 | .687 | 5/16-24 | 4,680 | .081 |
| EF6 | EFL6 | .3750 | .500 | .406 | 1.625 | 1.000 | .687 | .562 | .312 | .719 | .812 | 3/8-24 | 5,520 | .152 |
| EF8 | EFL8 | .5000 | .625 | .500 | 2.125 | 1.312 | .875 | .750 | .375 | .938 | 1.187 | 1/2-20 | 9,460 | .324 |
| EF10 | EFL10 | .6250 | .750 | .562 | 2.500 | 1.500 | 1.000 | .875 | .500 | 1.125 | 1.406 | 5/8-18 | 10,300 | .473 |

Chart Notes: 1. For standard lubrication fitting, add "Z" to suffix. Example: EM10Z 2. Zerks not available on 3/8" or 10mm and smaller rod ends.
3. This series is also available in a studded configuration. Specify by adding "S" to suffix. Example: EM10S

R-G Ball Joints

Steel Housing, Staked Design
with Rubber Grommet

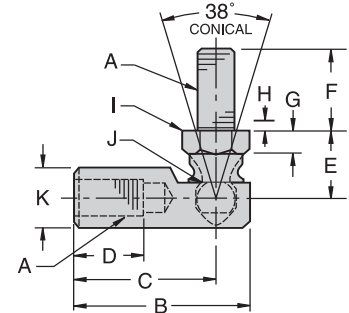

R-G CHART

| Part Number | | A | B | C | D | E | F | G | H | I | J | K | W.F. Width | W.F. Length | Tensile & Shear Strength (Pounds) | Force to Remove Ball Stud (Pounds) |
|-------------|-----------|---------|-------|-------|-------|-------|-------|------|------|------|------|------|------------|-------------|-----------------------------------|------------------------------------|
| Right Hand | Left Hand | UNF | ±.020 | ±.020 | MIN | ±.020 | ±.020 | REF | REF | REF | REF | REF | | | | |
| R103G | R103GLH | 10-32 | 1.156 | .875 | .469 | .359 | .438 | .094 | .062 | .312 | .177 | .375 | .312 | .250 | 295 | 690 |
| R107G | R107GLH | 1/4-28 | 1.219 | .969 | .500 | .469 | .562 | .125 | .094 | .375 | .193 | .437 | .375 | .281 | 882 | 1,005 |
| R108G | R108GLH | 5/16-24 | 1.406 | 1.125 | .562 | .531 | .687 | .156 | .094 | .437 | .232 | .500 | .437 | .281 | 1,587 | 1,282 |
| R109G | R109GLH | 3/8-24 | 1.687 | 1.375 | .750 | .687 | .875 | .187 | .094 | .500 | .287 | .625 | .500 | .312 | 2,437 | 1,700 |
| R110G | R110GLH | 7/16-20 | 2.375 | 1.937 | 1.125 | .875 | 1.125 | .250 | .125 | .625 | .412 | .750 | .625 | .375 | 3,390 | 2,700 |
| R111G | R111GLH | 1/2-20 | 2.375 | 1.937 | 1.125 | .875 | 1.125 | .250 | .125 | .625 | .412 | .750 | .625 | .375 | 3,390 | 2,700 |

Chart Notes: 1. Ball Joint can be ordered without the grommet by dropping the "G" suffix. Example: R108LH
2. R103G size is supplied with a wrap around grommet, not shown.

Material:

- **Ball Stud** - Low Carbon Steel, Case Hardened for Extended Wear Life, Zinc Plated, Yellow Dichromate Treated
- **Body** - Low Carbon Steel, Zinc Plated, Yellow Dichromate Treated

Applications:

Various integral ball joint applications, including:

- Lawn and garden equipment
- Construction
- Industrial equipment

Features:

- Steel body and ball stud "staked" design offers an economical solution to medium to heavy-duty ball joint applications
- Ball stud is case hardened for extended wear life
- Rubber grommet provides a durable seal against contaminants
- Can be used in a wide range of temperatures: -30°F — 250°F (-34°C — 121°C)
- Custom sizes and assemblies can be built to your specifications, including:
 - male to male or female to female
 - right or left-handed threads
- Many metric sizes available — consult factory
- Meets SAE specification J490 (Type G/Style 2)

S/SS/SC Ball Joints

Quick Disconnect with Spring or Spring Clip

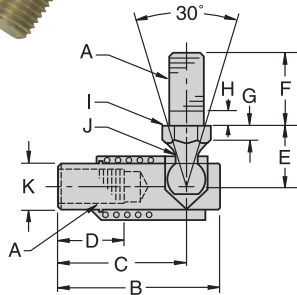
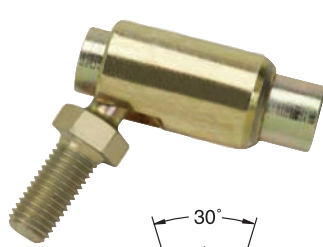

Type S

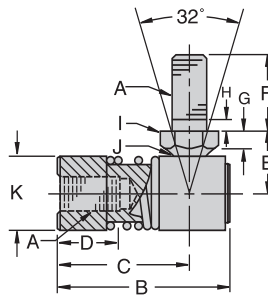
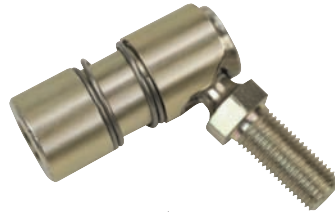

Type SS

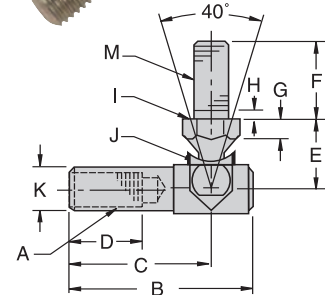
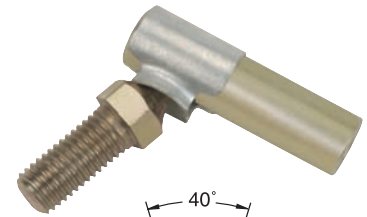

Type SC

S/SS/SC CHART

| Part Number | A UNF | B ±.020 | C ±.020 | D MIN | E ±.020 | F ±.020 | G REF | H REF | I REF | J REF | K REF | M UNF | Ball Diameter REF |
|-------------|----------|------------|------------|----------|------------|------------|----------|----------|----------|----------|----------|----------|----------------------|
| S103 | 10-32 | 1.094 | .906 | .437 | .437 | .437 | .125 | .062 | .312 | .171 | .312 | — | .253 |
| S107S | 1/4-28 | 1.094 | .906 | .531 | .469 | .562 | .141 | .062 | .312 | .171 | .312 | — | .253 |
| SS1002 | 1/4-28 | 1.250 | .969 | .531 | .469 | .562 | .125 | .078 | .375 | .192 | .562 | — | .345 |
| SS1003 | 5/16-24 | 1.453 | 1.125 | .594 | .531 | .687 | .125 | .094 | .437 | .224 | .625 | — | .403 |
| SS1004 | 3/8-24 | 1.750 | 1.375 | .812 | .687 | .875 | .156 | .109 | .500 | .273 | .750 | — | .491 |
| SC103 | 10-32 | 1.156 | .875 | .484 | .437 | .437 | .187 | .078 | .312 | .135 | .312 | 10-32 | .250 |
| SCS103 | 10-32 | 1.156 | .875 | .484 | .437 | .562 | .125 | .078 | .312 | .135 | .312 | 1/4-28 | .250 |
| SC107 | 1/4-28 | 1.250 | .969 | .531 | .437 | .562 | .125 | .078 | .312 | .135 | .312 | 1/4-28 | .250 |
| SCS107 | 1/4-28 | 1.250 | .969 | .531 | .437 | .437 | .125 | .078 | .312 | .135 | .312 | 10-32 | .250 |

Material:

- **Ball Stud** - Low Carbon Steel, Heat Treated, Zinc Plated, Yellow Dichromate Treated
- **Sleeve** - Low Carbon Steel, Zinc Plated, Yellow Dichromate Treated
- **Body: S and SS** - Low Carbon Steel
- **Body: SC** - Low Carbon Steel, Heat Treated, Zinc Plated, Yellow Dichromate Treated
- **Spring: S and SS** - Stainless Steel
- **Spring Clip: SC** - Hardened Spring Steel

Applications:

Light to medium-duty linkage applications, including:

- Cable assemblies
- Light industrial applications
- Agricultural, lawn and garden equipment
- Racing (throttle links)

Features:

- Three different configurations, all with steel ball stud, sleeve and body to match your load and cost requirements
- Quick pull back, “no tools required” disconnect assembly provides easier access, faster maintenance
- Can be used in a wide range of temperatures: -60°F — 250°F (-51°C — 121°C)
- Right and left-handed versions available
- Custom sizes and assemblies can be built to your specifications
- S/SS Series meets SAE J490 specification (S: type S/style 1, SS: type S/style 2)



Linking Motion
& Control...
The Cablecraft
Solution



Cablecraft Motion Controls Locations:

Globally Supported...Locally Serviced

● Cablecraft Motion Controls Locations

● Cablecraft Motion Controls Assembler Locations

Cablecraft[®]

Cablecraft Motion Controls

Cablecraft Motion Controls Headquarters

2110 Summit Street
New Haven, Indiana USA 46774
Tel 260 749-5105 Fax 260 749-5677

4401 South Orchard Street
Tacoma, Washington USA 98411
Tel 253 475-1080
Fax 253 474-1623

www.cablecraft.com

2789 Belleville Road
St. Matthews, South Carolina USA 29135
Tel 803 655-7300
Fax 803 874-3558

Diplocks Way-South Road
Hailsham, E. Sussex BN27 3JF, England
Tel (011-44) 1323-841510
Fax (011-44) 1323-845848

Distributed by: